

UCHIDA

AEROCUT G2

OPERATION MANUAL

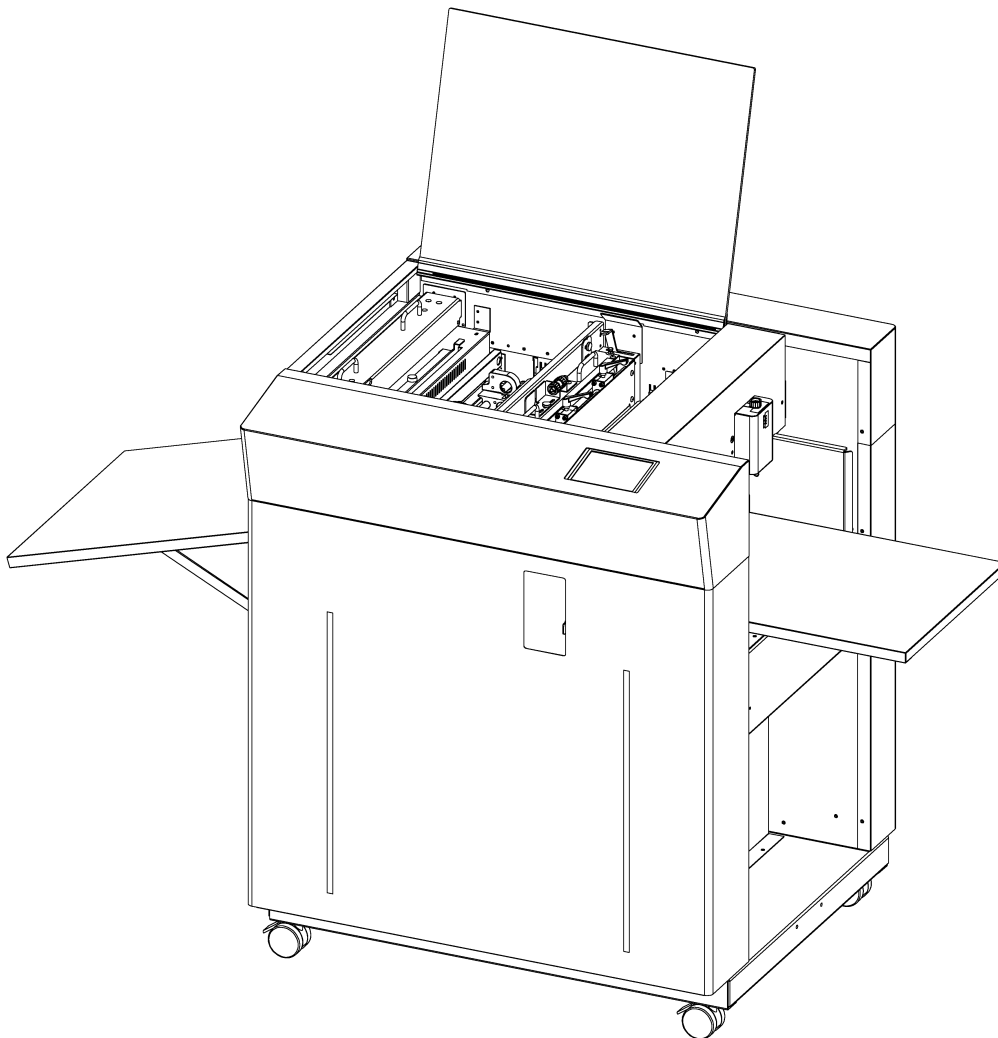

UCHIDA YOKO CO., LTD., TOKYO, JAPAN

Jul 23, 2012 USA

- Use machine only after reading the "Safety Instructions" given below carefully.
- These safety instructions are given to ensure that the machine will be used safely and properly and to prevent operators from sustaining harm and injuries.

Definition of Symbols and Notes

In this manual the following names and signs stand for possible dangers.



Danger

This symbol stands for immediate danger threatening the life and health of persons. Disregarding these instructions may cause severe damage to health and even serious injuries.



Caution

This symbol stands for an endangering situation that may occur. Disregarding these instructions may lead to slight injuries or damage to property.



Note

This symbol stands for notes, operational hints, and other useful information.

They are convenient for exploiting the machine's functional abilities.

SAFETY INSTRUCTIONS

Explanations of the illustrations used in the Safety Instructions are given as follows:

	<h3>Danger</h3>
<ol style="list-style-type: none">1. Don't open the cover of the equipment. There is a danger of receiving an injury or electric shock.2. Turn off the power supply beforehand when attaching or detaching the perforating blade. There is a danger of receiving an injury.3. Don't touch any rotating part. There is a danger of receiving an injury.	



Caution

1. Don't put a hand into the cover or a clearance between parts. There is a danger of receiving an injury.
2. Don't bring a hand, face, hair, sleeves of clothes and the like close to the rotating parts of the machine. There is a danger of receiving an injury.
3. Don't touch the blade point of the cutter. There is a danger of receiving an injury.
4. Don't touch the blade point of the perforating blade. There is a danger of receiving an injury.
5. Turn off the power supply beforehand when setting the feed table.
There is a danger of receiving an injury.
6. Turn off the power supply beforehand when setting the stacker. There is a danger of receiving an injury.
7. Turn off the power supply beforehand when setting the waste bin. There is a danger of receiving an injury.
8. Turn off the power supply beforehand when removing paper scraps. There is a danger of receiving an injury.
9. For the perforator, papers of weight 65 lbs (Cover stock) [176 g/m²] or less is to be used. Using heavier paper may cause a paper jam or mechanical failure.
10. Do not exceed the MAX level when stacking the paper. Exceeding it may cause a mechanical failure.
11. Turn off the power supply beforehand when starting maintenance or inspection. There is a danger of receiving an injury.
12. When you install a machine, please install to a place with no dust, and the place which is not influenced with a liquid. It becomes the cause of failure if the installation method is mistaken.
13. When you put a machine into operation, please change into the state where all covers were closed. If it works where a cover is opened, there is fear of an injury.

Introduction

Read this "Operation Manual" carefully before use. In particular, be sure to read "Safety Instructions" (page 2 to page 3) to ensure that the machine will be used properly.

Keep the manual at an appointed place with care so that it may be accessible whenever necessary.

The specifications of this product are subject to change for improvement. Therefore, don't mistake the "Operation Manual" of one product of the same model for that of another because descriptions in the "Operation Manual" of products of the same model may differ.



Contents

1. Before use	7
(1) Description and quantities of accessories	7
(2) Exterior features	8
(3) Installation	10
2. Operating instructions	11
(1) Checks before use	11
(2) Setting of stacker.....	11
(3) Waste box setting.....	12
(4) How to attach the business card stacker.....	12
(5) Paper setting.....	13
(6) Paper slant adjustment.....	14
(7) Separator adjustment.....	14
(8) Paper feed detection plate adjustment.....	15
(9) Blow rate adjustment.....	15
(10) Crease depth adjustment	16
(11) How to remove the crease unit.....	17
(12) How to attach the perforator	18
(13) How to adjust the perforation location	19
(14) How to adjust the depth of perforation.....	21
(15) How to replace the perforation Lower Blade.....	22
3. Operational method.....	23
(1) Basic operation.....	23
(2) Slitter initial location movement.....	23
(3) Format selection.....	24
(4) Free entry	27
(5) User program retrieval (MANU SET).....	28
(6) User program registration (MANU SET).....	29
(7) FLEX entry	31
(8) User program retrieval (FLEX MODE).....	34
(9) User program registration (FLEX MODE).....	35
(10) Setting of slitter and feed table	37
(11) Operation number cancellation.....	37
(12) Manual operation and Speed Change	38
(13) Cut mark on/off selection.....	39
(14) Automatic operation.....	40

4. Instructions for use	4 1
(1) If the machine stops during operation	4 1
(2) If Paper scrap remains on the machine	4 2
(3) Details concerning errors.....	4 3
(4) If the cut measurement does not match the input value	4 9
5. Product specifications	5 0
6. Equipment, Electric circuit and parts	5 2
7. Ordering consumables, etc.	5 5

1. Before use

(1) Description and quantities of accessories

Electric power cord	1pc.	
Hexagonal wrench	0.08" X 1pc.	
Tweezers	1pc.	
Waste ejector	1pc.	
Instruction manual	1pc.	
Waste box	1pc.	
Paper guide (Large)	1pc.	
Paper guide (Small)	5pc.	

(2) Exterior features

1. Name of parts

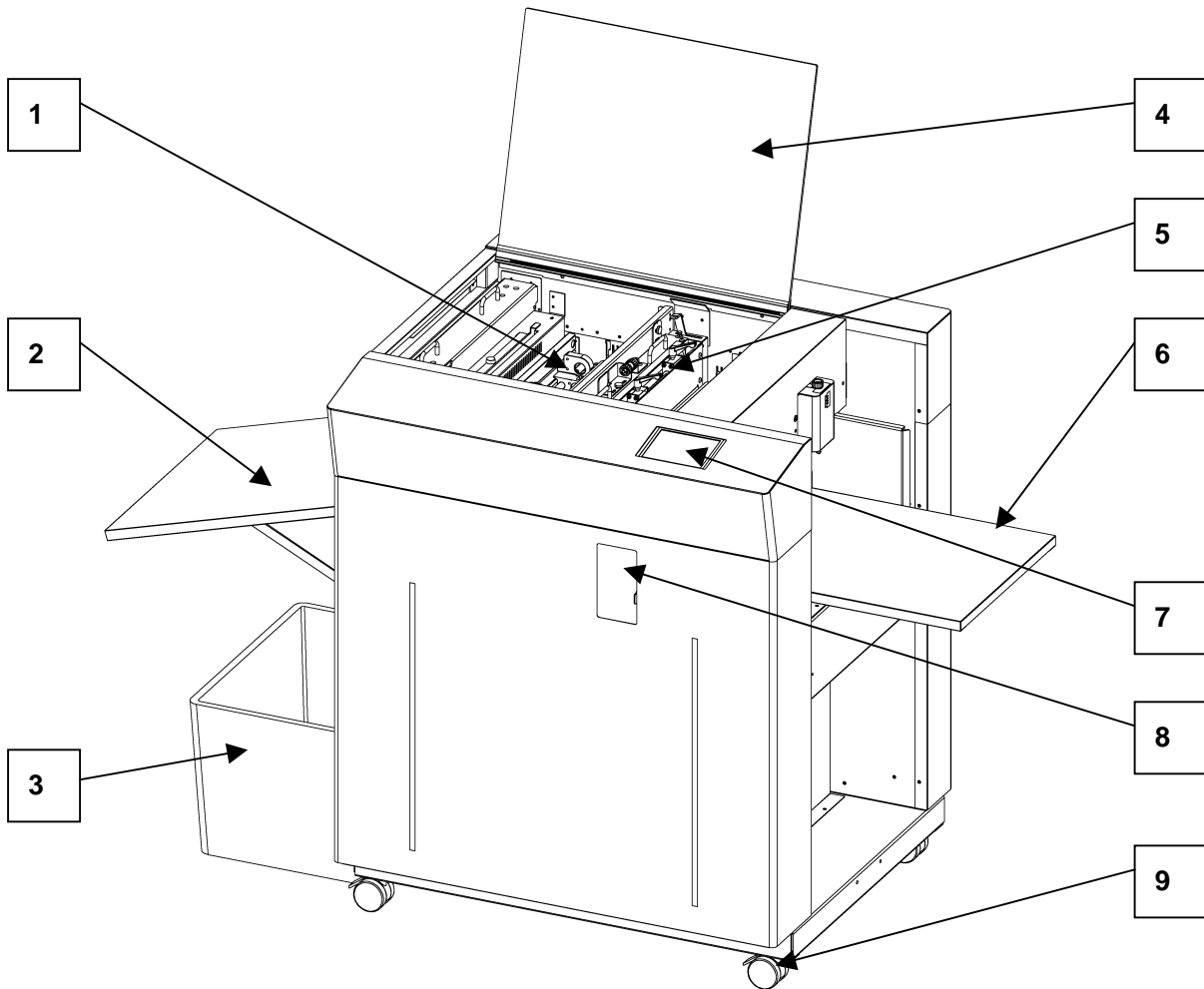

1. Slitter	6. Feed Table
2. Stacker	7. Touch Panel
3. Waste Box	8. Adjustment Door
4. Safety Cover	9. Caster
5. Perforator cartridge	

2. Electric-power-related points

The electric power switch and the inlet are located inside the machine, below the feed table.

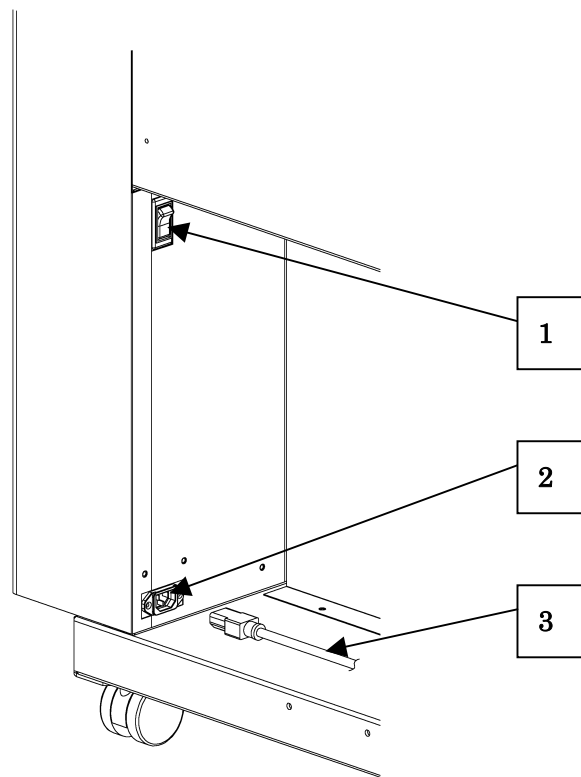



1	Power switch	① When it is set at "I", the power is turned on. ② When it is set at "O", the power is turned off.
2	Inlet	Plug in the electric power cord here.
3	Electric Power Cord	Plug this to the inlet.

(3) Installation

1. The machine installation method

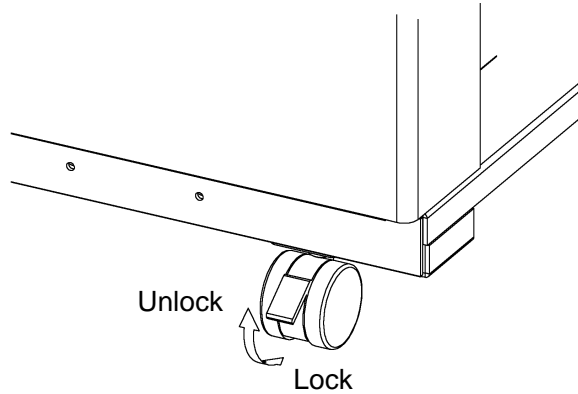
Please be sure to LOCK a caster brake after making it move to the target position, when installing a machine.



 Caution	
	When you install a machine, please install to a place with no dust, and the place which is not influenced with a liquid. It becomes the cause of failure if the installation method is mistaken.

2. How to remove accessories

- ① Loosen the screws to remove the chute guide.
- ② Remove the chute screws.
- ③ Lift the chute and take out the waste box.
- ④ The accessory case is inside the waste box.
- ⑤ Reposition the chute guide.

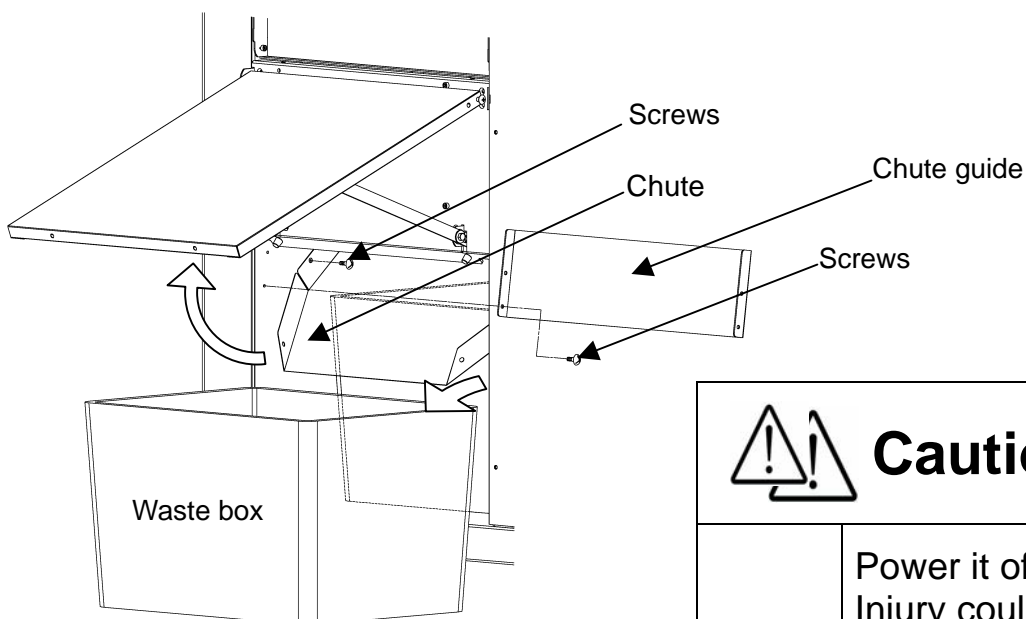

 Caution	
	Power it off. Otherwise, Injury could occur.

2. Operating instructions

(1) Checks before use



Check the following before operation. 

- ① Is the electric power turned off?
- ② Is the feed table set?
- ③ Is the stacker set ?
- ④ Is the electric power cord plugged in?
- ⑤ Is the waste box set?

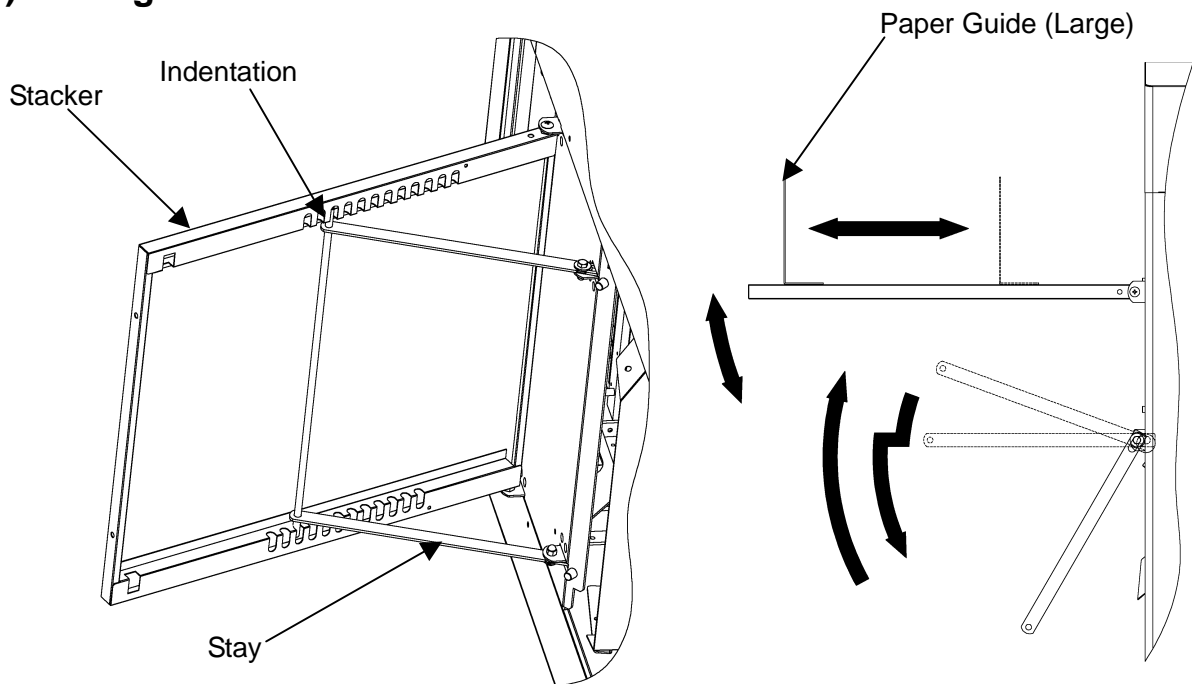
(2) Setting of stacker



- ① Open the stacker and set the stays in the indentation of the back of the stacker at an appropriate angle to allow smooth paper ejection.
- ② Adjust the large paper guide according to the paper size.

 Caution	
	Power it off. Otherwise, Injury could occur.

(3) Waste box setting

- ① Set the waste box under the stacker.

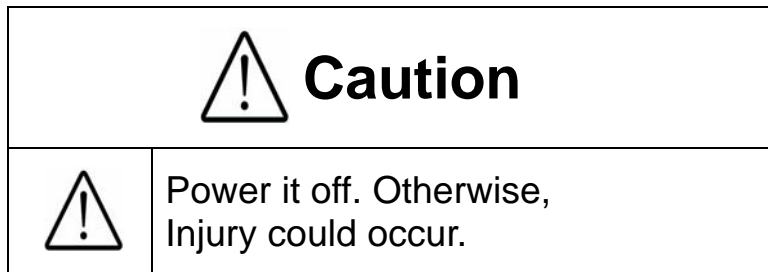
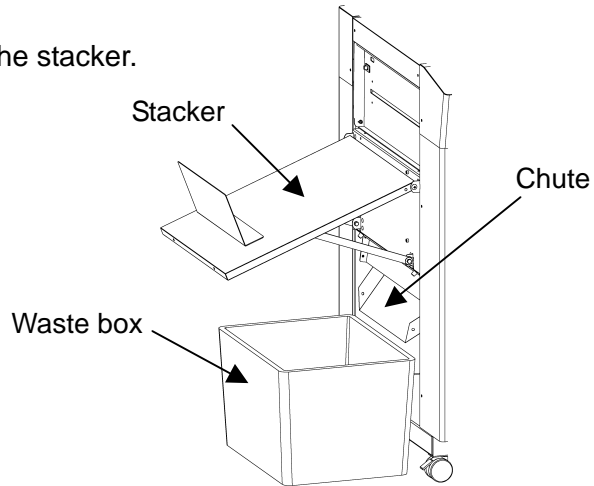

(4) How to attach the business card stacker.

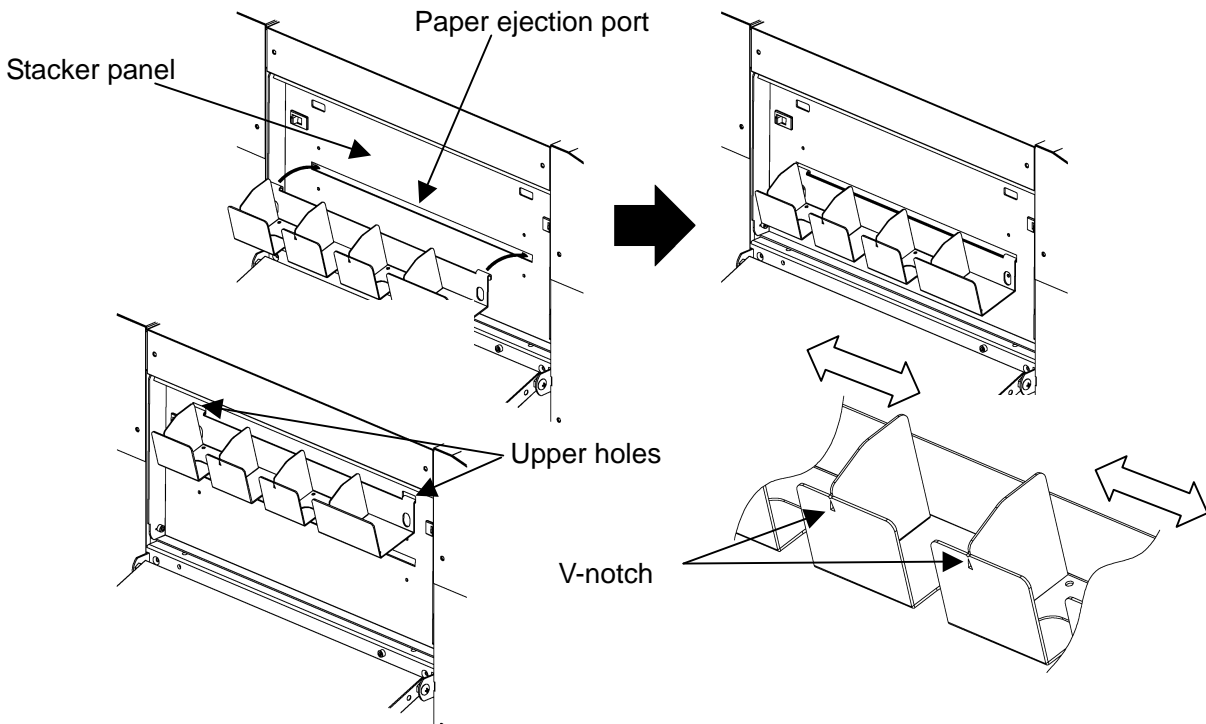

- ① Hang the business card stacker on Paper ejection port of Stacker panel.
- ② Find the V- notch to see where to put the business card stacker.
- ③ When it is not used, it may be hooked to the upper holes in the stacker panel.

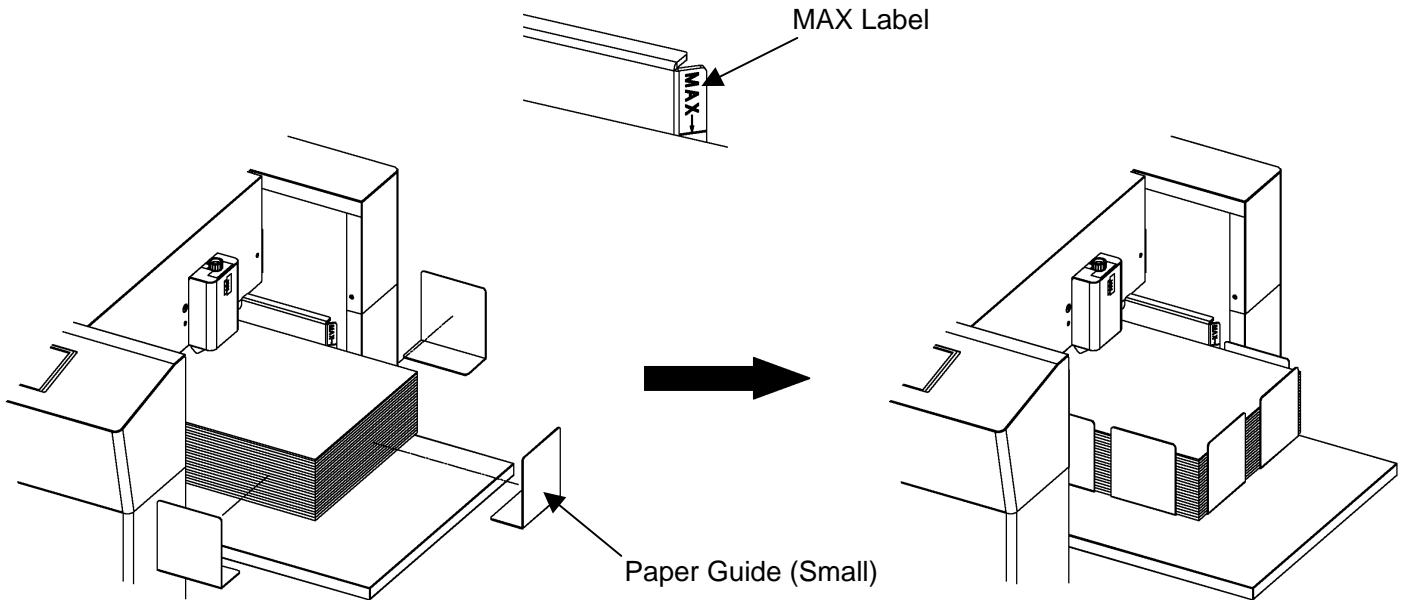

(5) Paper setting

- ① Press **SET** to lower the feed table.
- ② Separate the sheets of paper well and place them on the feed table.
- ③ Fix the paper with the small paper guides.
- ④ Make sure that the paper stack does not exceed the MAX label.



 Caution	
	Ensure that the paper stack does not exceed the MAX label, as it may cause a mechanical failure.
	Separate the sheets of paper well, as it may cause a paper jam.

(6) Paper slant adjustment

- ① Open the adjustment door on the front side of the main body.
- ② When the printing is tilted, turn the dial as shown in the drawing below to make it straight.
- ③ Turning the dial up will tilt the paper to the right, whereas turning it down will tilt the paper to the left.
- ④ A graduation of “0” indicates the straight position.

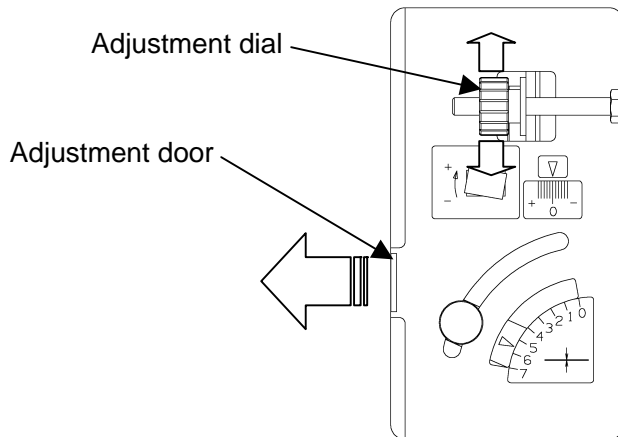

(7) Separator adjustment

- ① Open the adjustment door on the front side of the main body.
- ② Loosening the knob, adjust it upward when double feeds tend to occur, and adjust it downward when the paper is not smoothly fed.

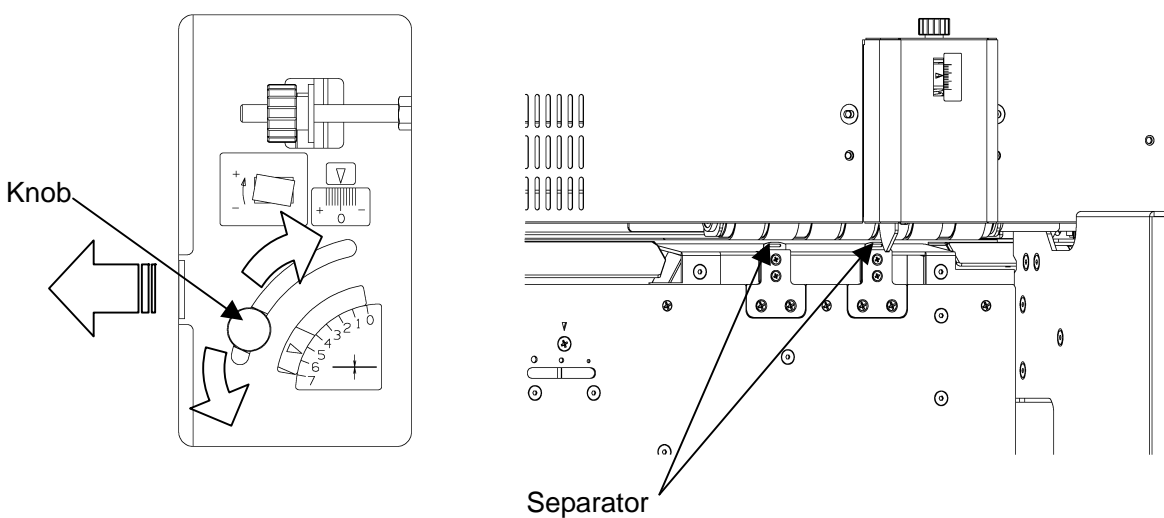

(8) Paper feed detection plate adjustment

- ① Use the paper feed detection plate adjustment dial for this adjustment.
- ② Turn it counterclockwise (down) when the paper tends to be doubly fed, and turn it clockwise (up) when the paper is not smoothly fed.
- ③ When the paper tends to be slantly fed, move the plate upward.

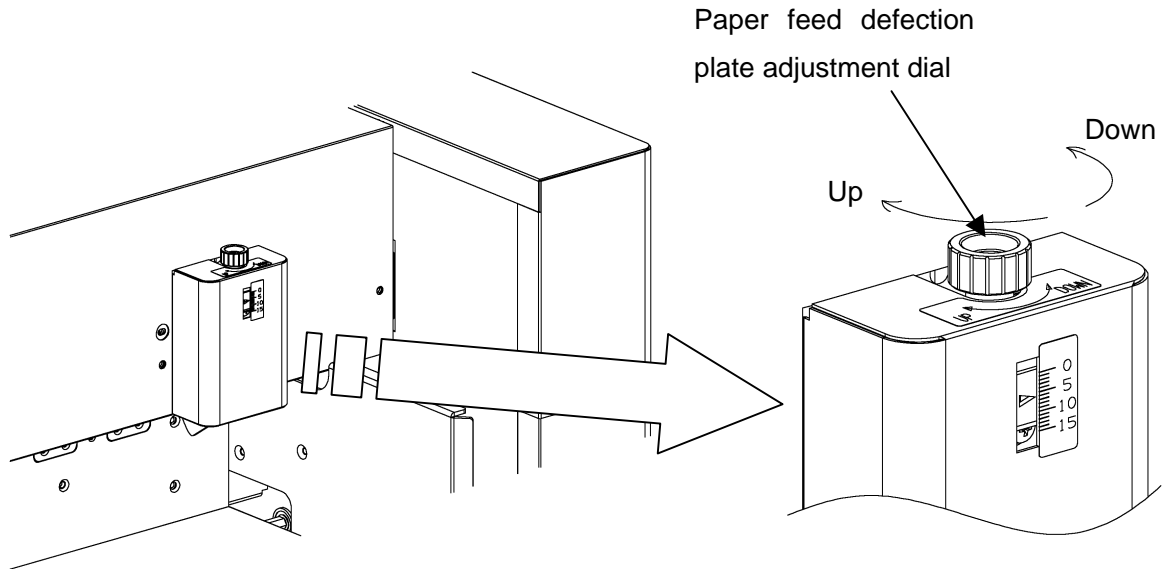

(9) Blow rate adjustment

- ① Power it off.
- ② Loosen a screw located on the far side of the paper feeder and put the tip of the screwdriver into the slit below to adjust it to the right and left.
- ③ Adjust to the right (lower blow rate) when the paper tends to be doubly or slantly fed or it is thin, and to the left (higher blow rate) when the paper is not smoothly fed or it is thick.

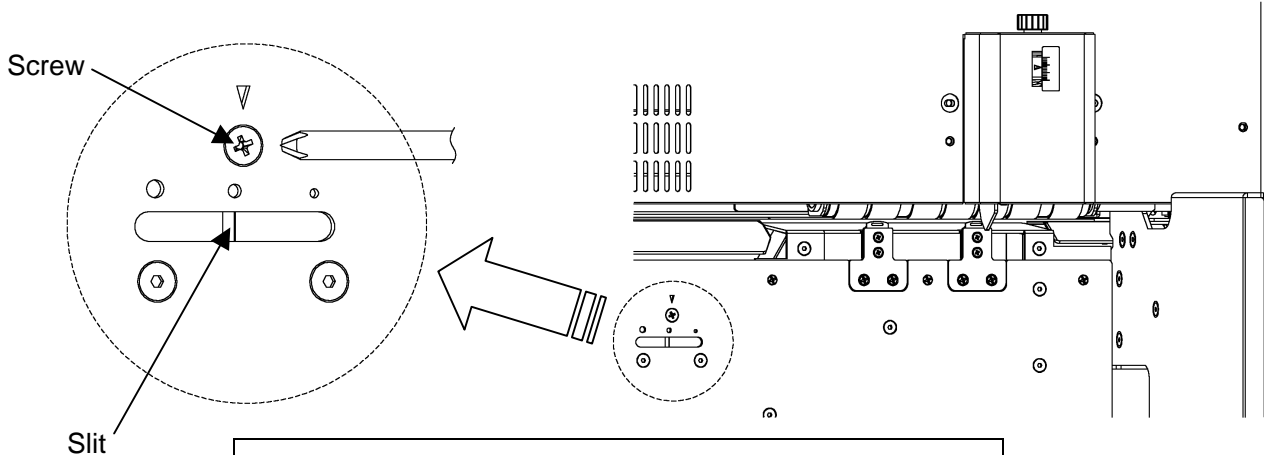

Caution





Power it off. Otherwise,
Injury could occur.

(10) Crease depth adjustment

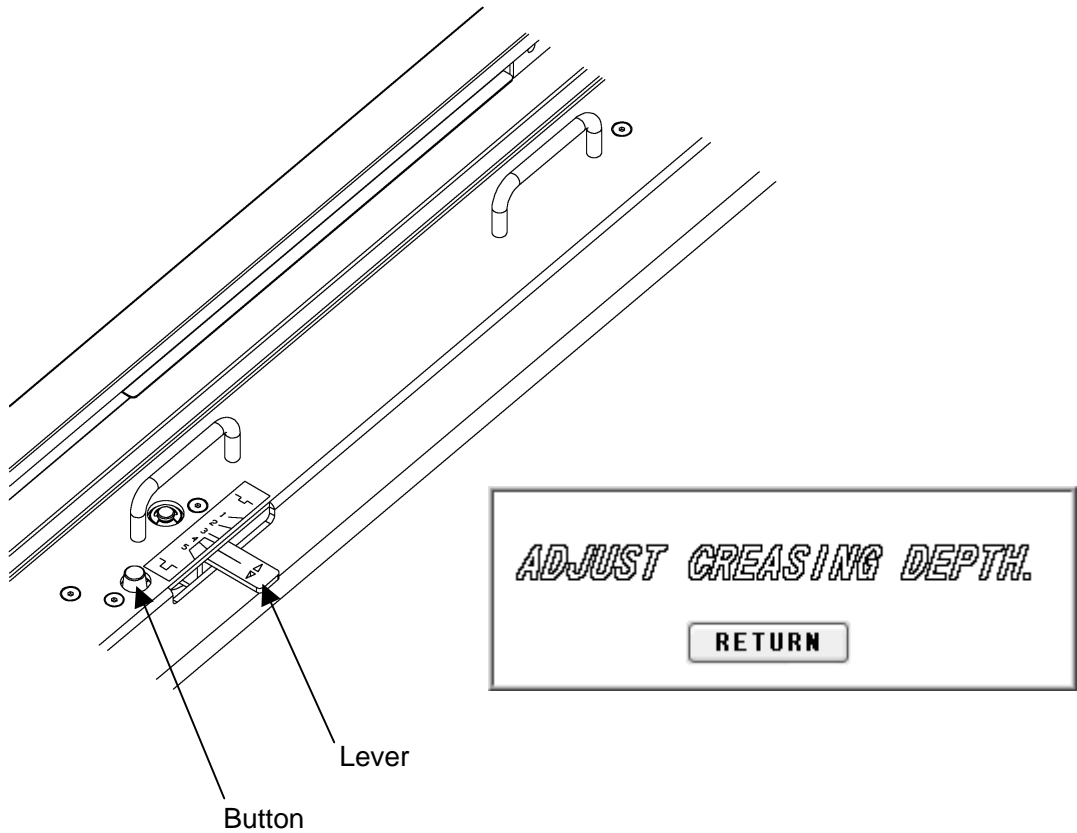
- ① The sign shown in the drawing below will be displayed when using the creaser.
- ② Turn the dial shown in the drawing below to adjust the crease depth.
- ③ The depth will become the most shallow by choosing Level 1 and the deepest by choosing Level 5.
- ④ When choosing Level 4 or 5, turn a lever while pressing a button on the near side. To return to Level 3 or lower, simply turn the lever.
- ⑤ When selecting Levels 4 and 5, be careful of the paper thickness. Placing the crease too deep may cause a paper jam or a mechanical failure when the paper is thick.



 Caution	
	Avoid the combined use of the creaser and the perforator, as it may cause a paper jam or a machine failure.
	When selecting Levels 4 and 5, be careful of the paper thickness. Placing the paper too deep may cause a paper jam or a machine failure when the paper is thick.

(11) How to remove the crease unit

- ① Power it off.
- ② Be sure to hold the upper handles of the crease unit with both hands. Pushing it to the far side, lift the handle on the near side to remove the upper part of the crease unit.
- ③ Then, hold the knobs of the crease unit with both hands and pull it out upward.

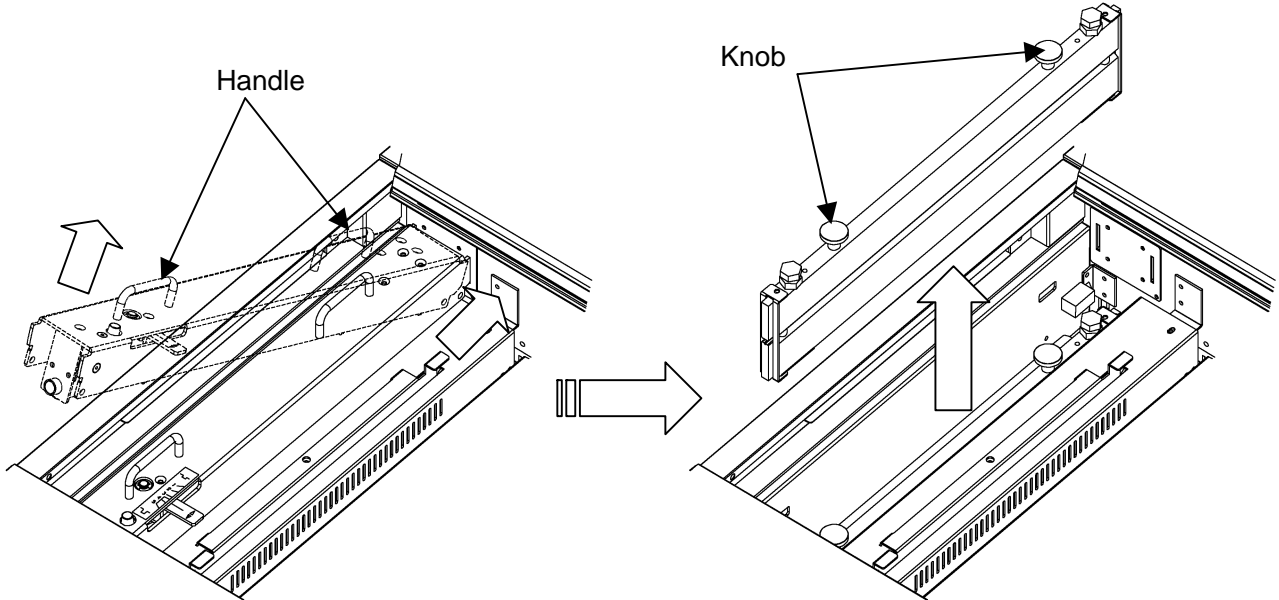

Caution





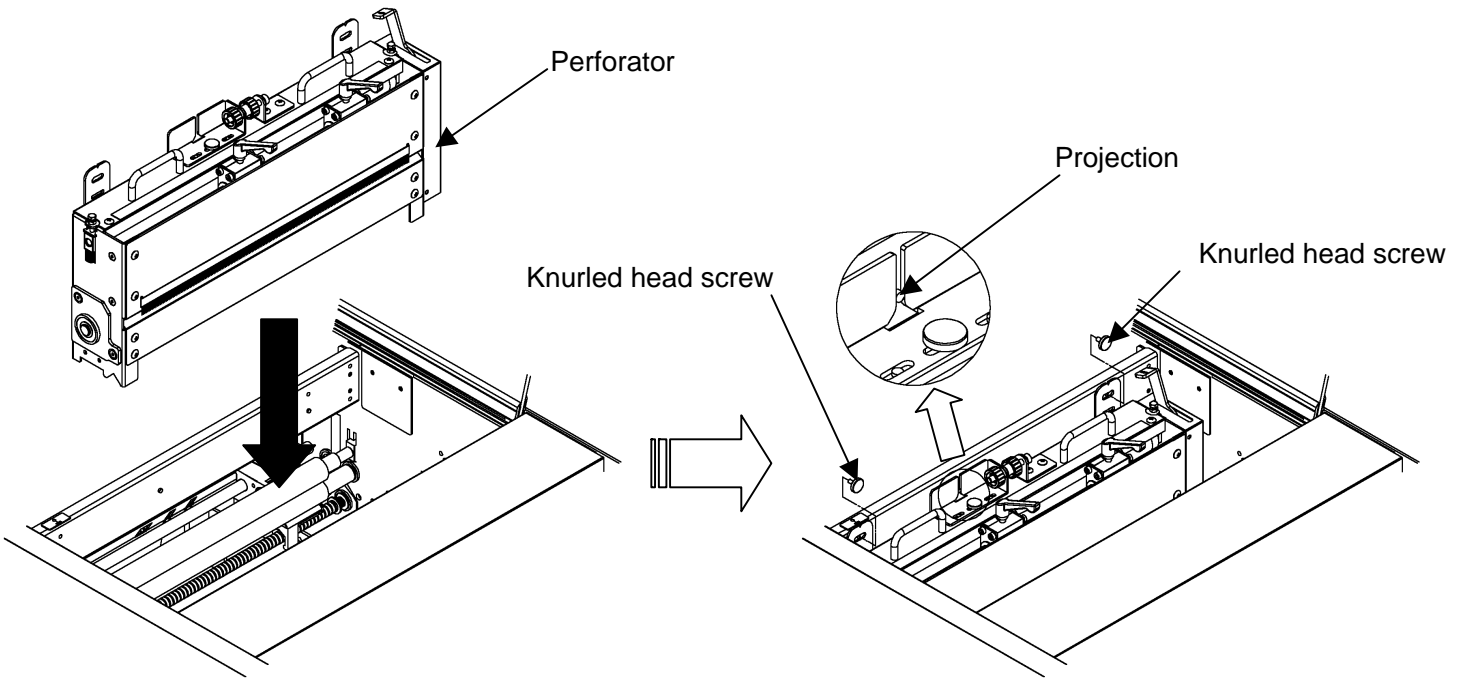

Power it off. Otherwise,
Injury could occur.

(12) How to attach the perforator

- ① Power it off.
- ② Be sure to hold the perforator with both hands and attach it as shown in the figure.
- ③ Attach it in such a manner that the projection is positioned as shown in the figure.
- ④ Fix at 2 spots with knurled head screws.
- ⑤ The target paper weight for the perforator is 65 lbs (Cover stock) [176 g/m²] or less.



 Caution	
	Power it off. Otherwise, Injury could occur.
	The maximum paper weight for use is 65 lbs (Cover stock) [176 g/m ²] for the perforator. Using a heavier paper may cause a paper jam or a mechanical failure.
	Combined use of the perforator and creaser may cause a paper jam or a mechanical failure

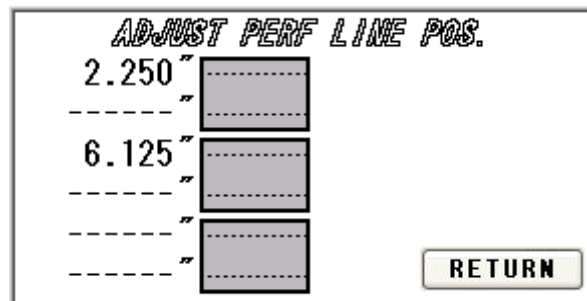
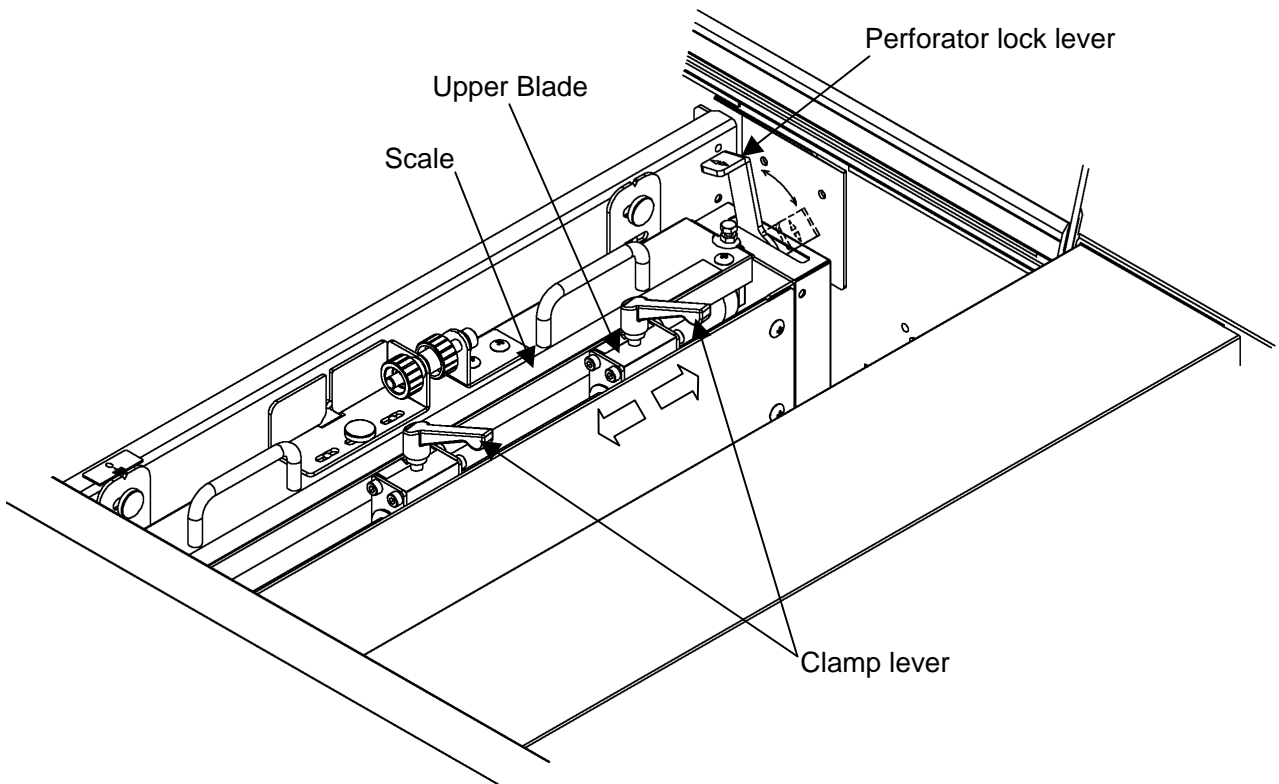

(13) How to adjust the perforation location

- ① When using the perforator, the screen will display where to fix the perforator, as shown below.
- ② If the upper blades are positioned to come into contact with the lower blades, the upper blade position can be adjusted with the perforator attached to the main body.
- ③ Shift the perforator lock lever to the right. Loosen the clamp levers, move the perforator to the desired position based on the scale, and tighten the clamp levers firmly.
- ④ Shift the perforator lock lever to the left to finish this adjustment.

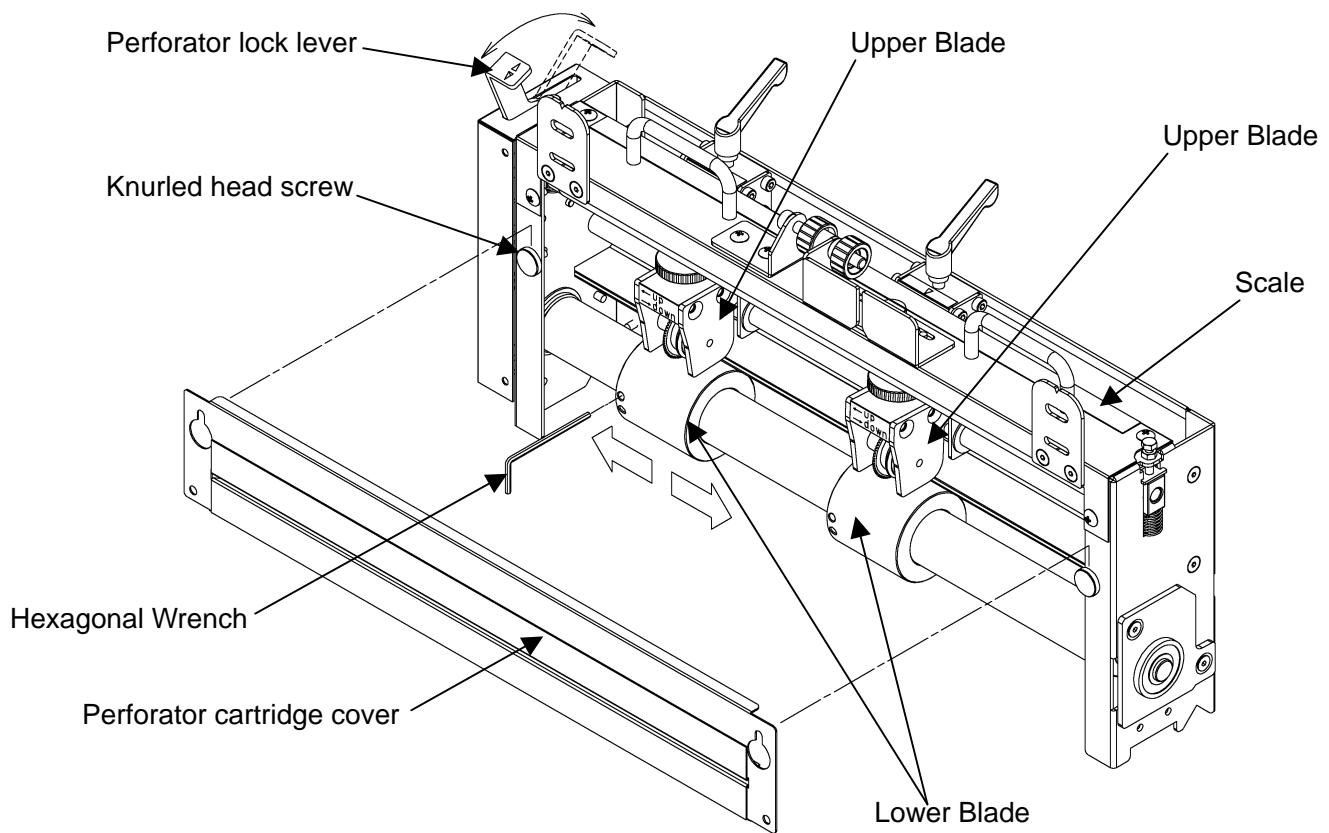

- ⑤ If the upper blades are not positioned to come into contact with the lower blades, remove the perforator from the main body for adjustment.
- ⑥ Remove the perforator in the reverse order of the procedure described in (12) (How to attach the perforator).
- ⑦ Loosen the two knurled head screws to remove the perforator cartridge cover.
- ⑧ Shift the perforator lock lever to the right. Loosen the clamp levers, move the perforator to the desired position based on the scale, and tighten the clamp levers firmly.
- ⑨ Then, loosen screws with an accessory wrench and adjust the lower blade position to near the center of the upper blades.
- ⑩ Put the perforator back on the main body and you are finished with this adjustment.



 <h2 style="display: inline;">Caution</h2>	
	<p>Avoid the combined use of the creaser and the perforator, as it may cause a paper jam or a mechanical failure.</p>
	<p>Avoid contacting the cutting edge of the perforating blade. Otherwise, injury could occur.</p>

(14) How to adjust the depth of perforation

- ① Change in the paper thickness, recommend you adjust the depth of Perforation.
- ② The height of the upper blades can be individually adjusted.
- ③ Remove the perforator by reversing the procedure described in (12) (How to attach the perforator).
- ④ Shift the perforator lock lever to the right and raise the upper blades.
- ⑤ Adjust a height adjustment screw in the up direction if it is cutting into too deeply, and in the down direction if not cutting into sufficiently.

Up=Shallow

Down=Deep

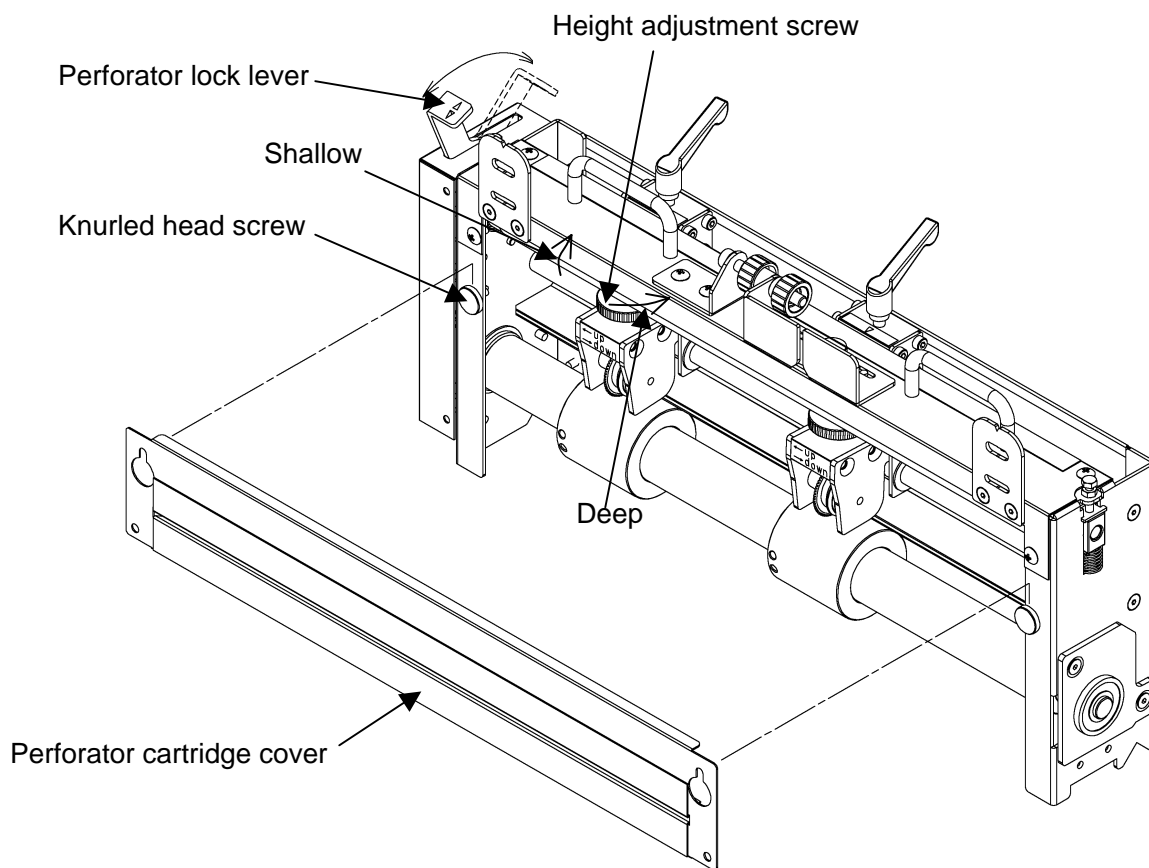

Caution



Avoid contacting the cutting edge of the perforating blade. Otherwise, injury could occur.

(15) How to replace the perforation Lower Blade

- ① As the lower blades of the perforator repeatedly cut the paper, the paper finish condition degrades.
- ② If this is the case, shift the lower blade position slightly.
- ③ If the lower blades cannot be shifted any more, it is necessary to replace them.
- ④ Remove the perforator by reversing the procedure described in (12) (How to attach the perforator).
- ⑤ Shift the perforator lock lever to the right and raise the upper blades.
- ⑥ Remove the hexagon socket set screws from the lower blades.
- ⑦ Remove two screws, followed by the cartridge bearing lid.
- ⑧ Remove the ball bearing, plain washer, and spring, and pull out the lower blades.
- ⑨ Replace them with new ones and assemble by reversing the removal procedure.

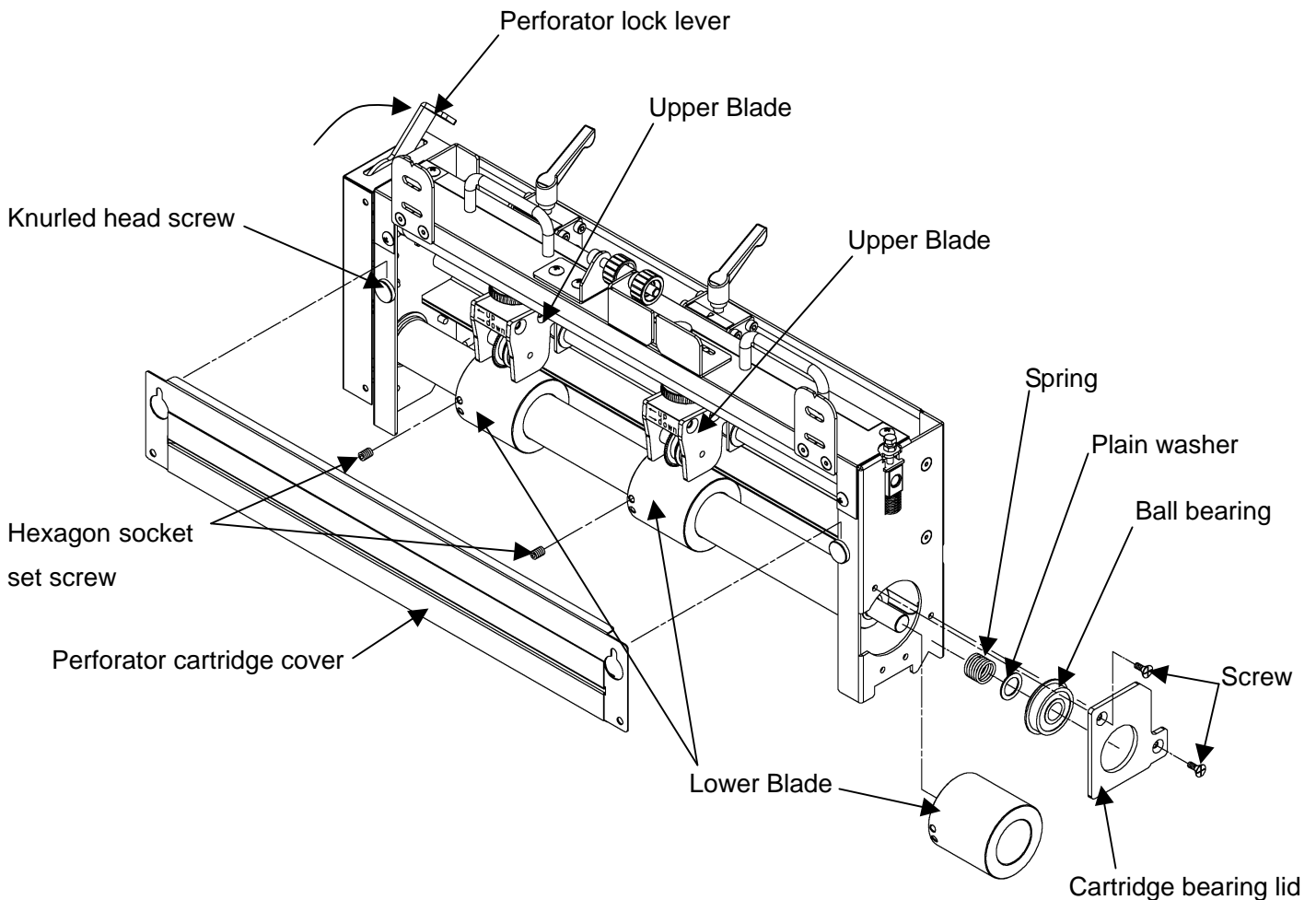

Caution



Avoid contacting the cutting edge of the perforating blade. Otherwise, injury could occur.

3. Operational method

(1) Basic operation

- ① Turning the power on.
- ② Slitter initial location movement (When turning the power on initially and after adjusting the head location)
- ③ Format selection/free entry, user program retrieval, etc.
- ④ Slitter and table setting
- ⑤ Creaser adjustment (when using the creaser)
- ⑥ Perforator adjustment (when using the perforator)
- ⑦ Paper setting
- ⑧ Sample cutting
- ⑨ Input value correction and size correction
- ⑩ Start of operation

(2) Slitter initial location movement (When initially turning the power on and after adjusting the head location)

- ① Turn the power on.
- ② Press INITIAL POSITION from the operation screen.
- ③ The slitter will move to the initial position.
- ④ The INITIAL POSITION sign will change to SET upon completion.

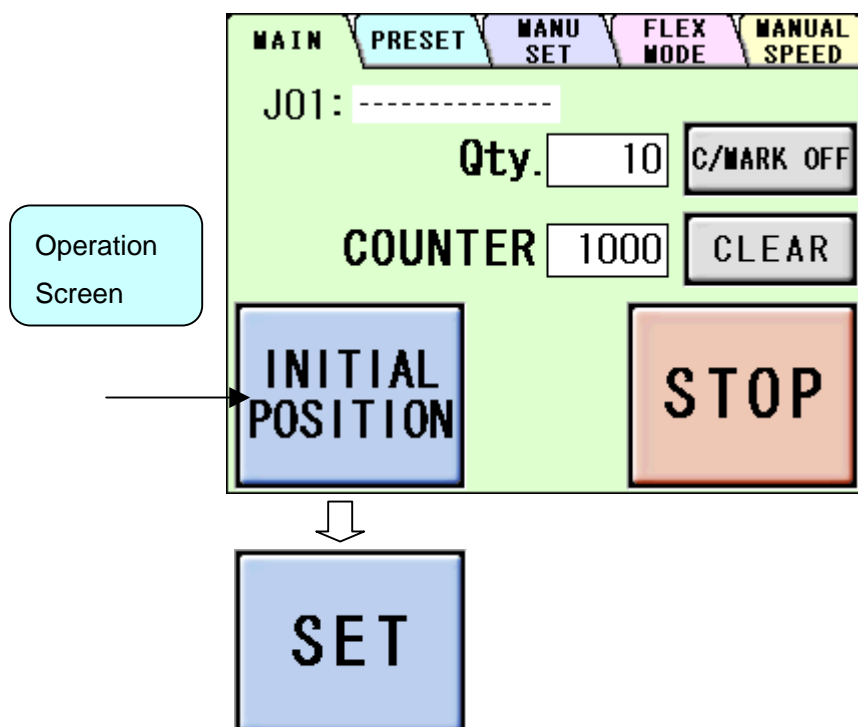

(3) Format selection

- ① Press PRESET.

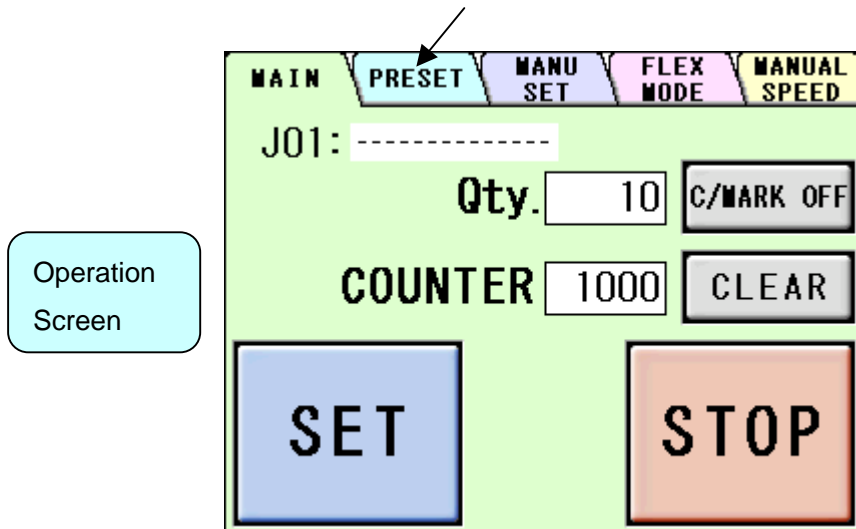

- ② Select the paper type to be used.

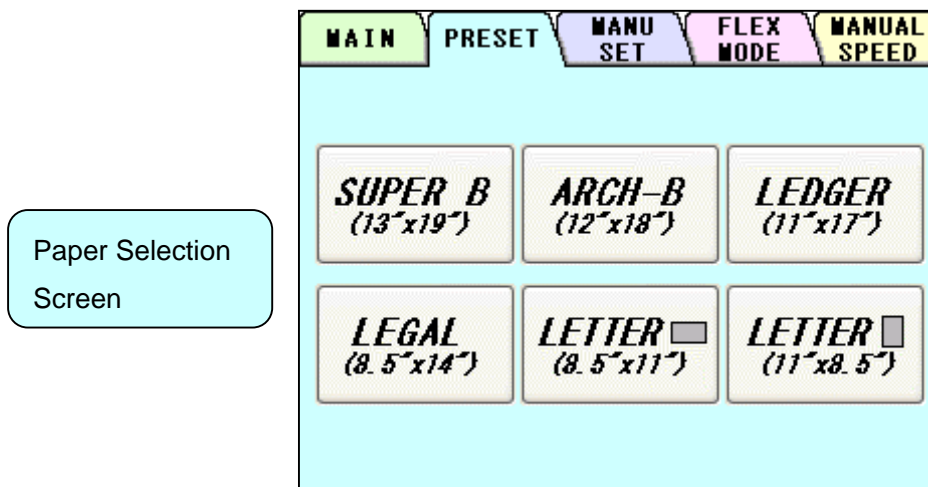

③ Select the cutting pattern.

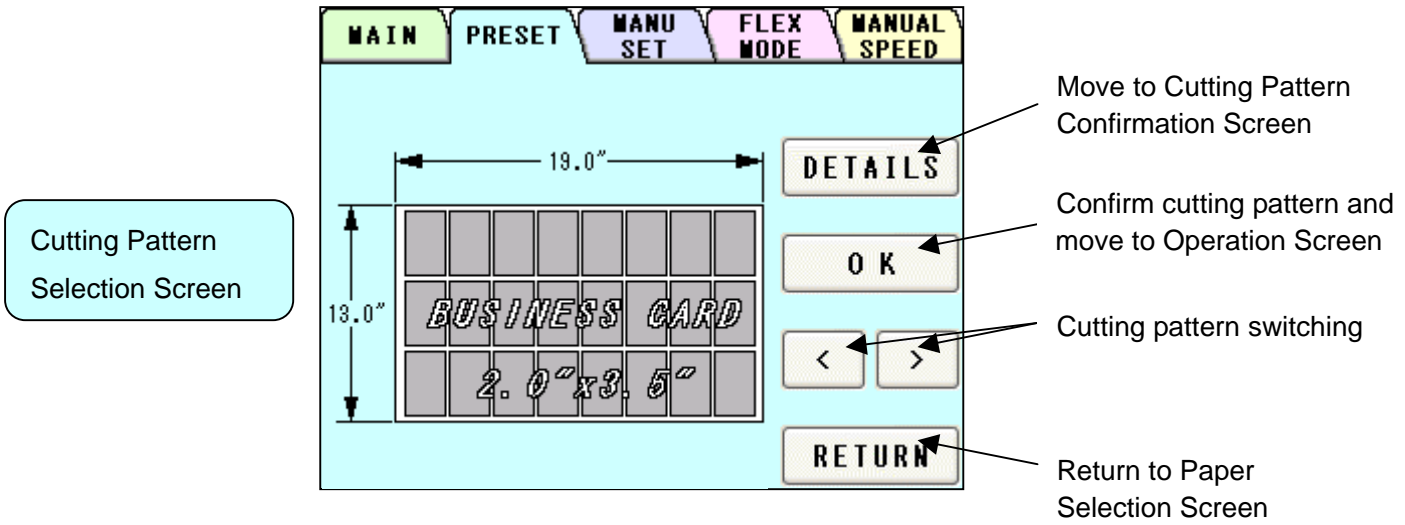

④ Cutting pattern content confirmation and partial correction

Press A through N to make corrections. O, P and Q are automatic calculations. It is possible to enter in inches up to the 3rd decimal place.

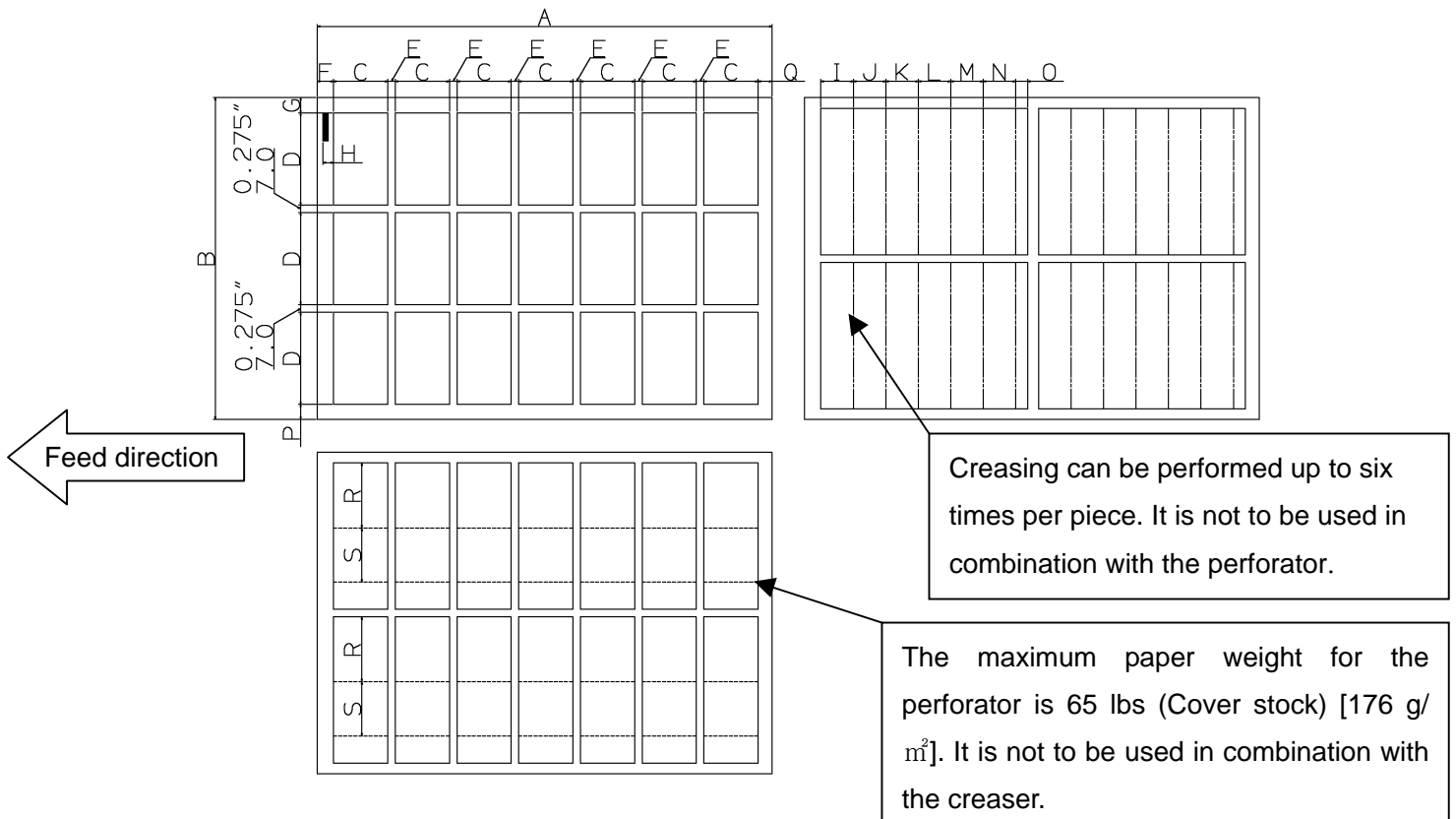

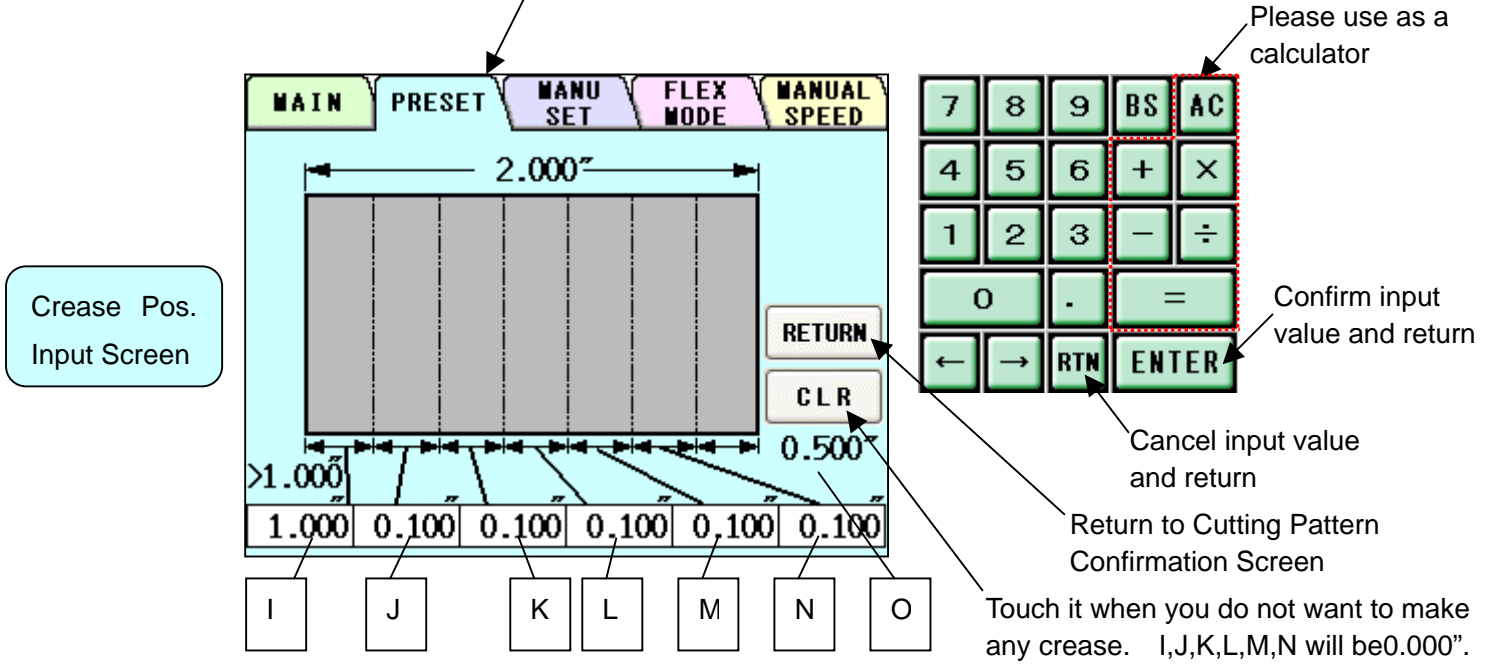
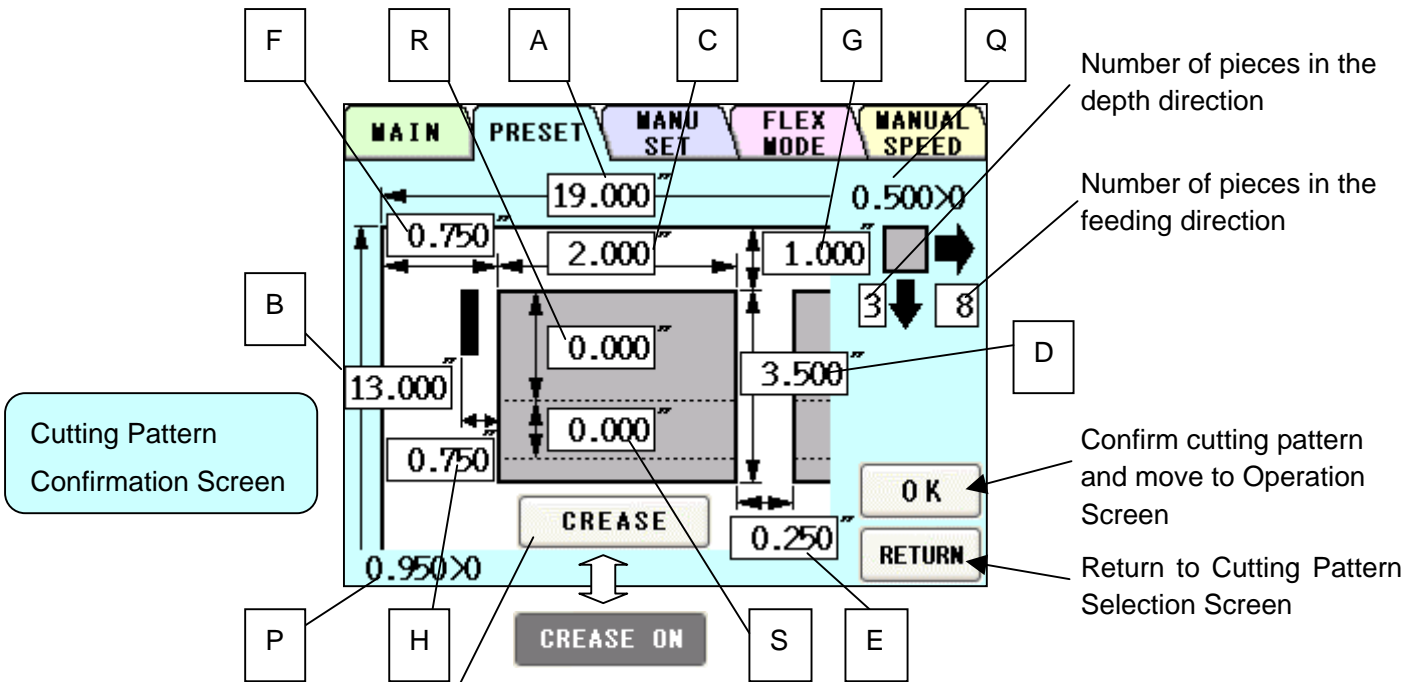

(4) Free entry

- ① Press MANU SET.

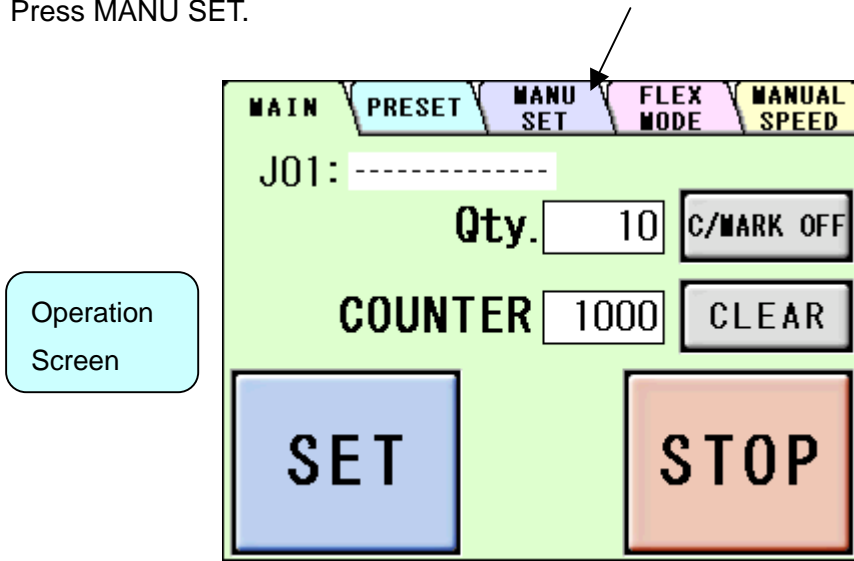

- ② The operation is almost the same as (3)-④.

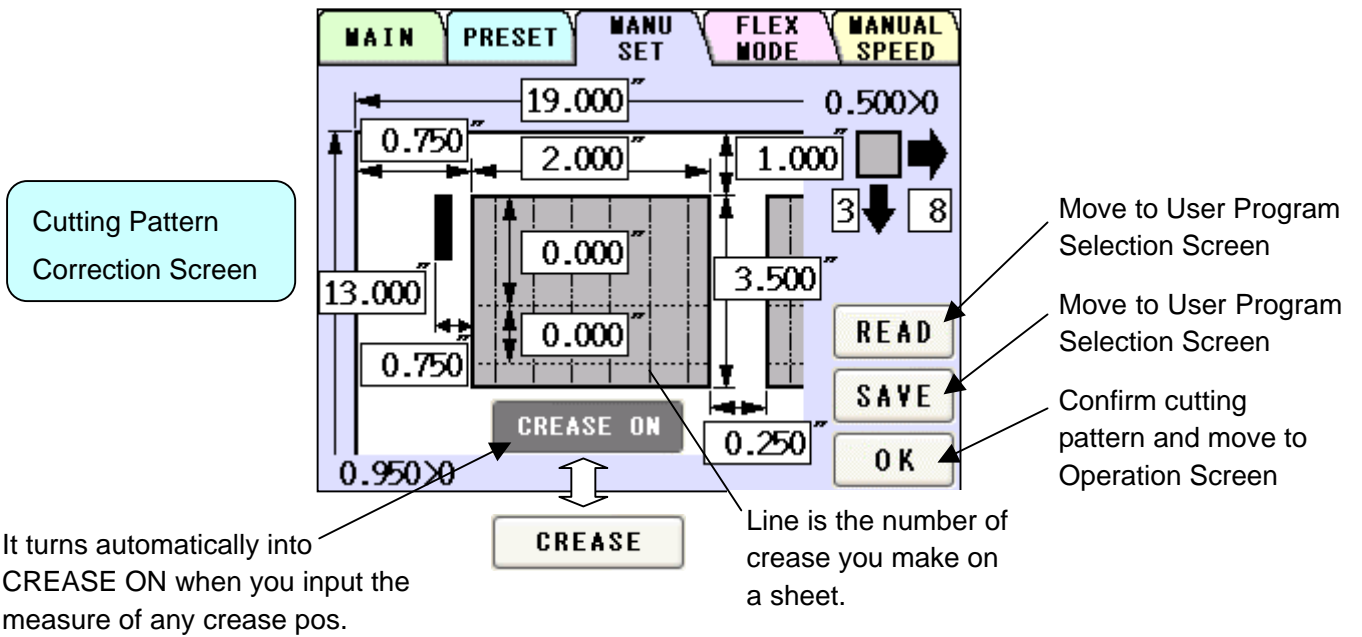

(5) User program retrieval (MANU SET)

- ① 60 user program can be registered.
- ② Press the button of the name you wish to retrieve.

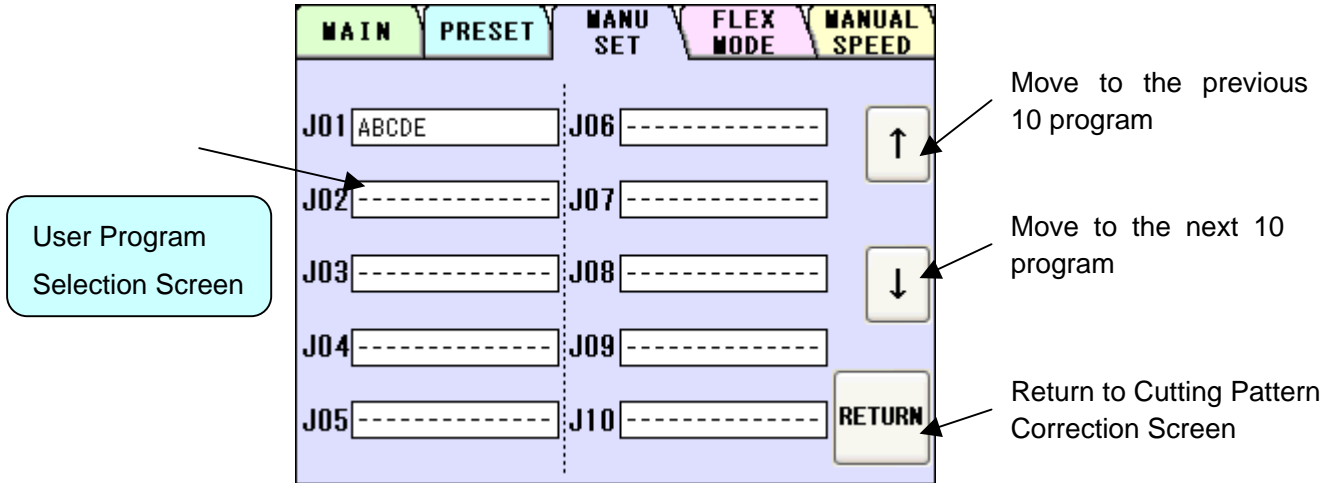

- ③ Confirm the details of the program for retrieval.

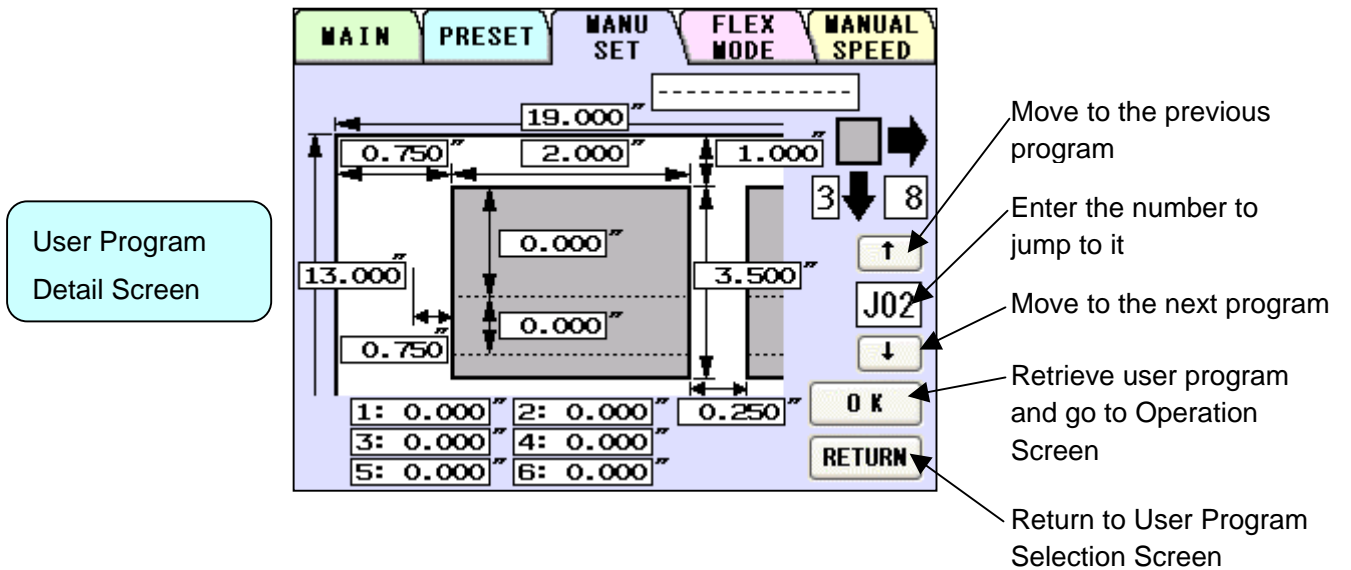

(6) User program registration (MANU SET)

- ① 60 user program can be registered.
- ② Press the button in which you wish to make a registration.

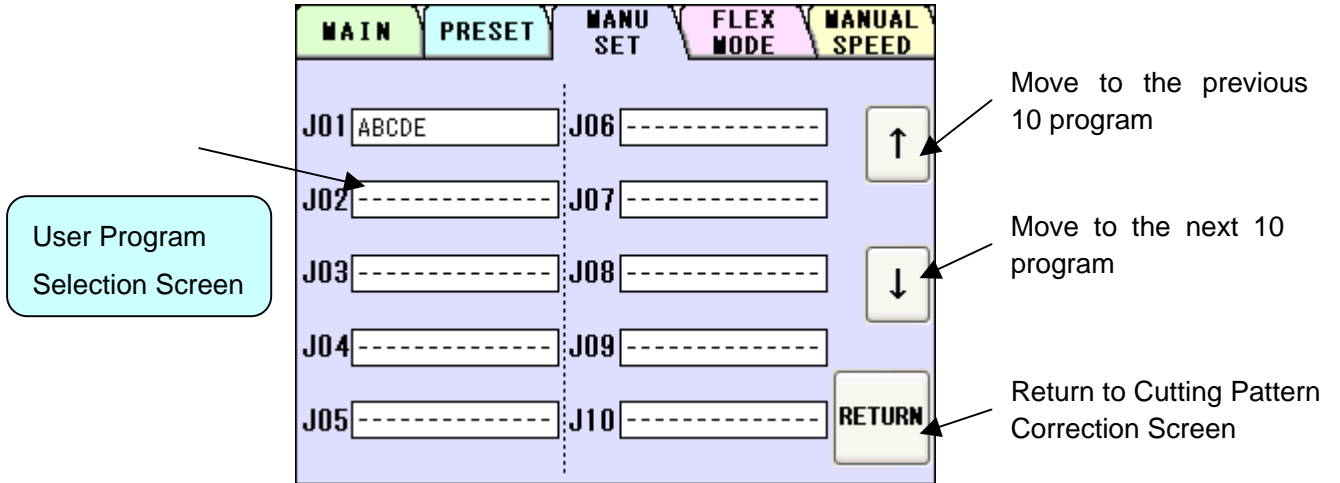

- ③ Confirm the program stored in the selected place.

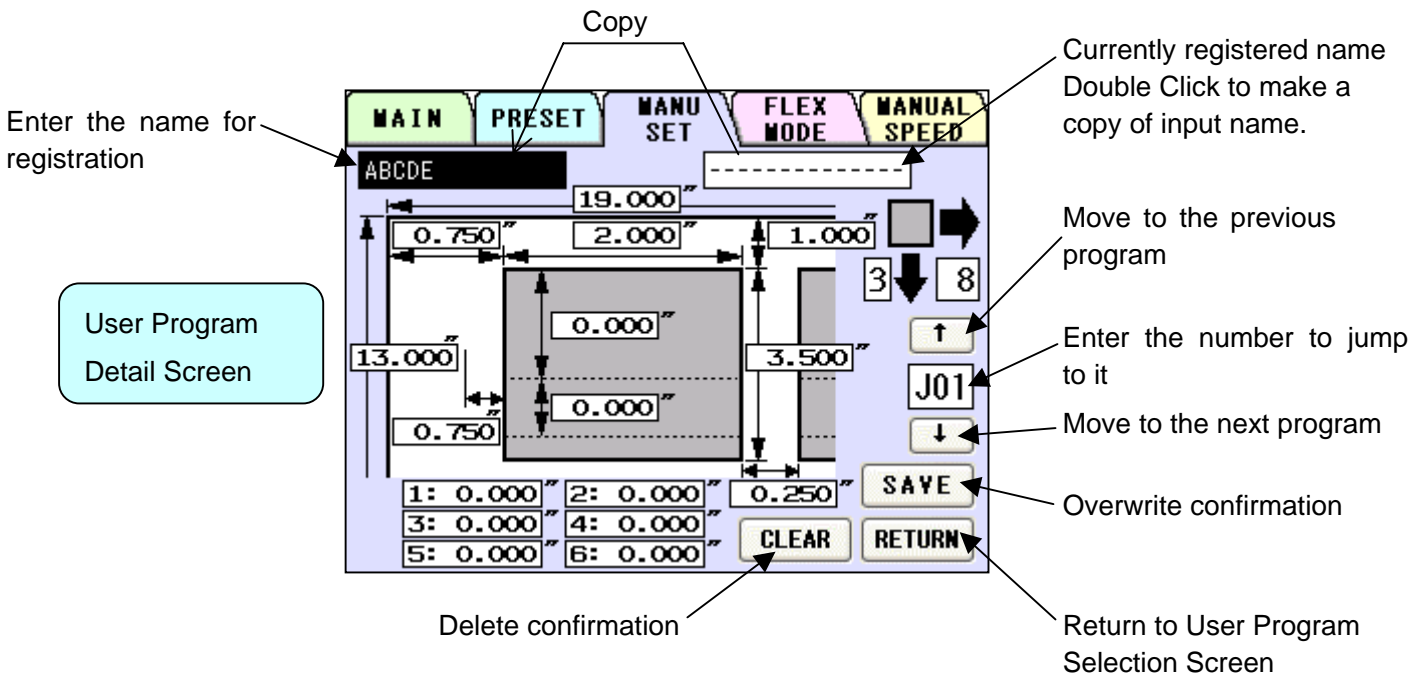

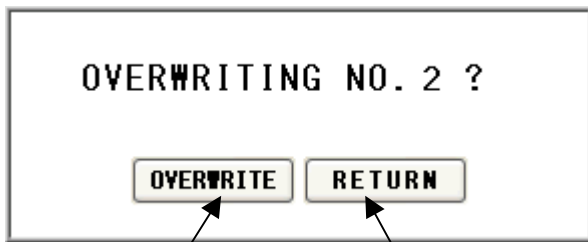
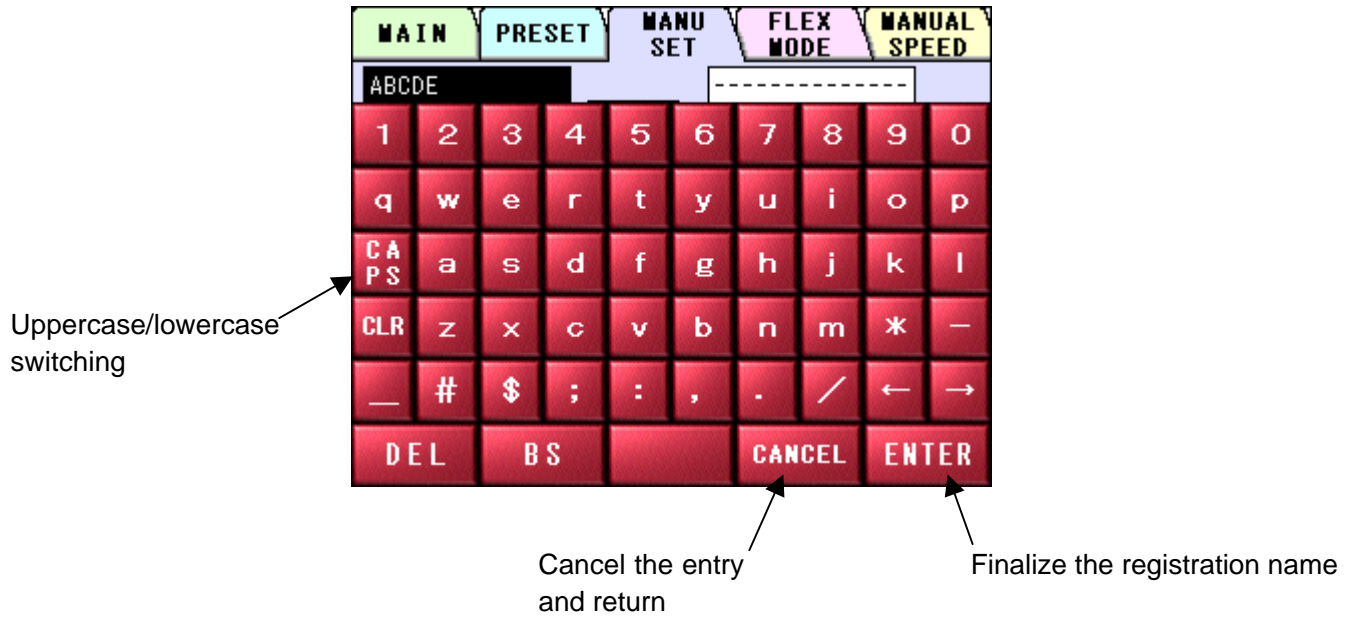

For overwriting and move to Cutting Pattern Correction Screen

Return to User Program Detail Screen

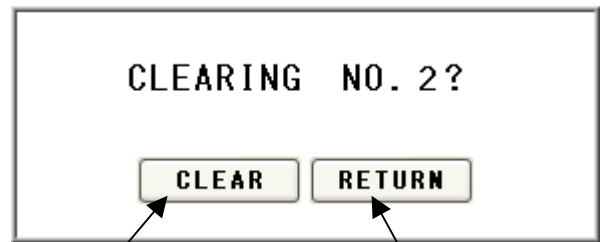

Delete and move to User Program Detail Screen

Return to User Program Detail Screen

(7) FLEX entry

- ① Press FLEX MODE.

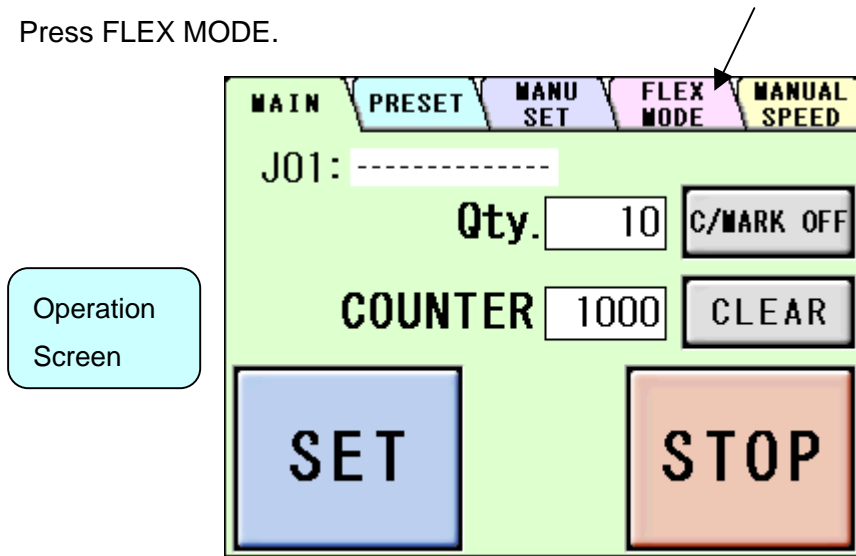

- ② This input screen allows you to freely select the guillotine or the crease up to 20 pitches for the paper of non-identical size unacceptable in the MANUSET screen, paper with special cutting patterns, and paper completely passing through.

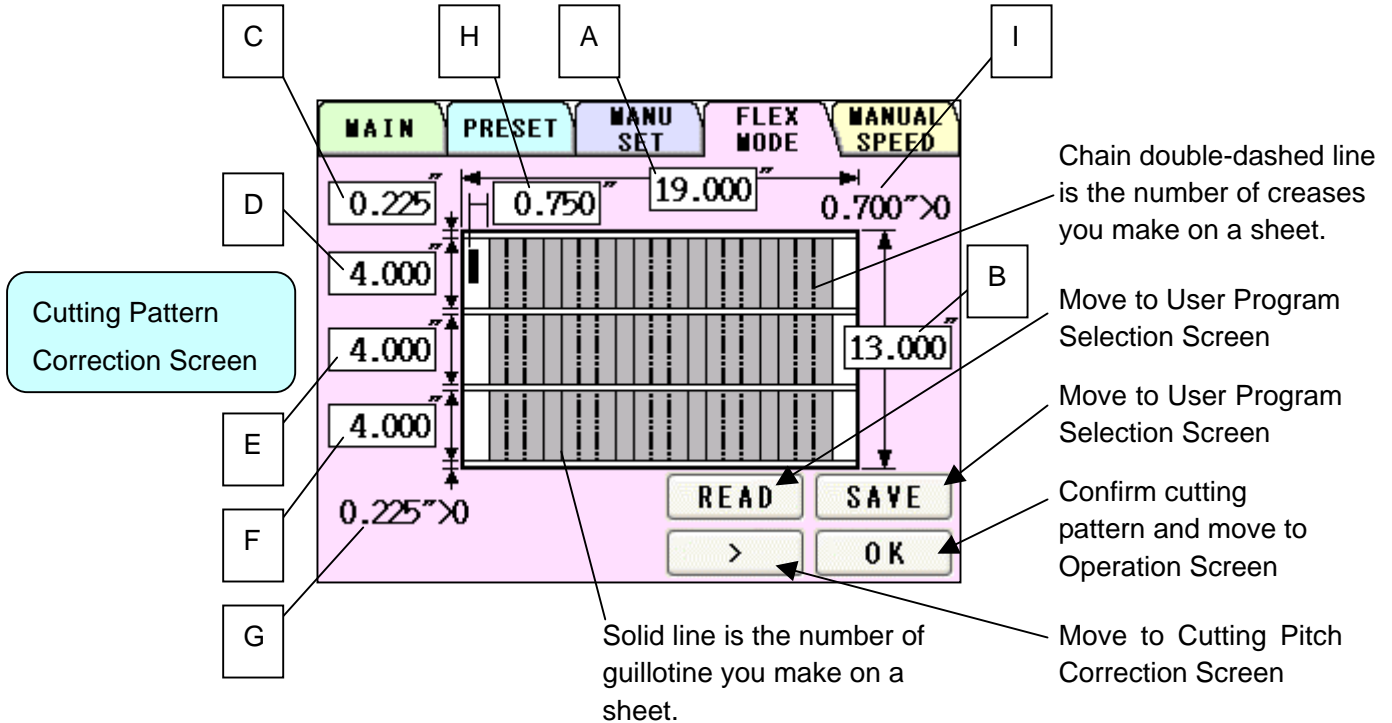

- ③ This screen allows you to input each pitch from No. 1 to No. 20. The adjacent switches are used for selecting no operation, guillotine, or creaser. Every time the switch is pressed, the selected operation changes.

- : No operation
- CUT : Guillotine
- CRS : Crease

- ④ If the pitch of 0.000" is input, all the pitches after that one are corrected to 0.000" (no operation).
- ⑤ Pressing SAME PITCH copies the No. 1 pitch and its relevant operation to No. 2 to No. 20 pitches.

Cutting Pitch Correction Screen

MAIN	PRESET	MANU SET	FLEX MODE	MANUAL SPEED
				0.700" > 0
①	0.750 CUT	⑧ 0.900 CUT	⑤ 1.350 CRS	
②	0.900 CRS	⑨ 0.450 CUT	⑥ 0.900 CUT	
③	1.350 CRS	⑩ 0.900 CRS	⑦ 0.450 CUT	
④	0.900 CUT	⑪ 1.350 CRS	⑧ 0.900 CRS	
⑤	0.450 CUT	⑫ 0.900 CUT	⑨ 1.350 CRS	
⑥	0.900 CRS	⑬ 0.450 CUT	⑩ 0.900 CUT	
⑦	1.350 CRS	⑭ 0.900 CRS		
			SAME PITCH	
			<	OK

Confirm cutting pattern and move to Operation Screen

Move to Cutting Pattern Correction Screen

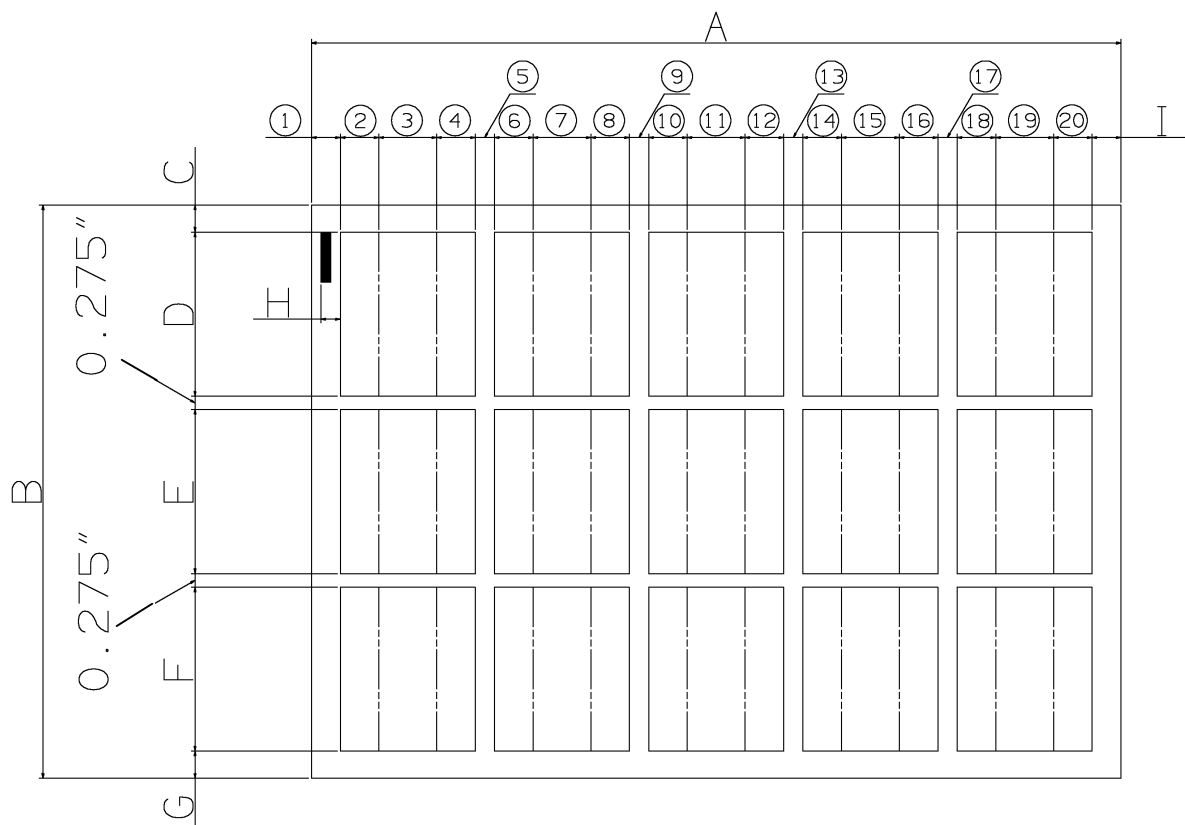

- ⑥ When letting the paper pass through completely (when passing only via the perforator or when using as the feeder), input the paper size for A and B, and the same dimension as B for D. Input "0" for all the remaining dimensions.
- ⑦ Make sure for the first cut line must be 0.785" or shorter from the edge of the paper. If you want to cut off 0.785" or more, please cut off 0.785" or less at first and then cut off again and again. If you try to move the slitter cut line at 1.855 or more position, the slit will be ejected on Paper ejection table instead of waste box. If you try to move the slitter between 0.785" and 1.855" from the edge of the paper, error occurs.

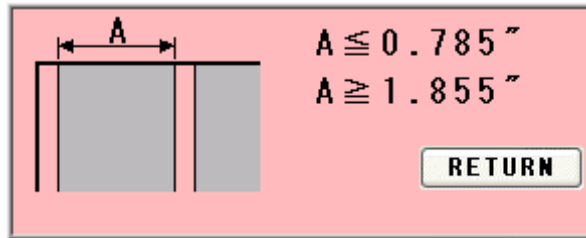

- ⑧ If you try to move the slitter to the position that is physically impossible, the error occurs.

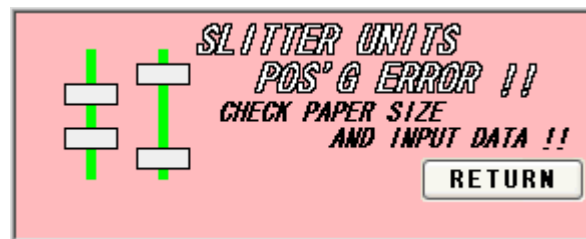

(8) User program retrieval (FLEX MODE)

- ① 30 user program can be registered.
- ② Press the button of the name you wish to retrieve.

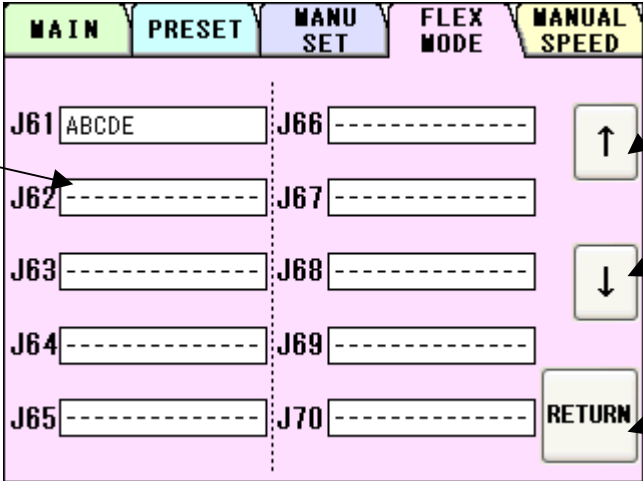

The screen displays a grid of program names from J61 to J70. J61 contains 'ABCDE', while others are dashed lines. Navigation buttons (up, down, return) are on the right.

User Program Selection Screen

- Move to the previous 10 program
- Move to the next 10 program
- Return to Cutting Pattern Correction Screen

- ③ Confirm the details of the program for retrieval.

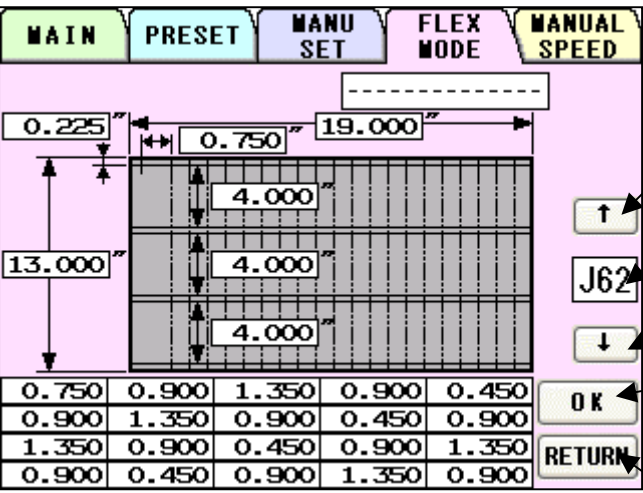

The screen shows a detailed drawing of a part with dimensions. A table of dimensions is at the bottom. Navigation buttons (up, down, OK, return) are on the right.

User Program Detail Screen

- Move to the previous program
- Enter the number to jump to it
- Move to the next program
- Retrieve user program and go to Operation Screen
- Return to User Program Selection Screen

0.750	0.900	1.350	0.900	0.450
0.900	1.350	0.900	0.450	0.900
1.350	0.900	0.450	0.900	1.350
0.900	0.450	0.900	1.350	0.900

(9) User program registration (FLEX MODE)

- ① 30 user program can be registered.
- ② Press the button in which you wish to make a registration.

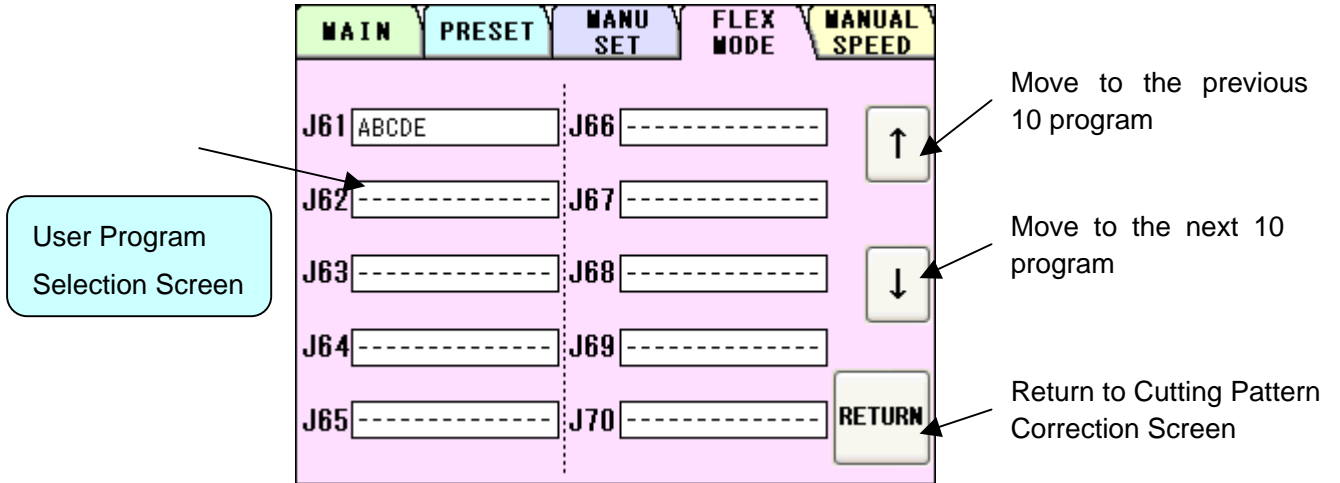

The screen displays a grid of program slots from J61 to J70. The top navigation bar includes MAIN, PRESET, MANU SET, FLEX MODE, and MANUAL SPEED. A callout box on the left identifies the screen as the 'User Program Selection Screen'. On the right, three buttons are labeled: an up arrow for 'Move to the previous 10 program', a down arrow for 'Move to the next 10 program', and a 'RETURN' button for 'Return to Cutting Pattern Correction Screen'. The J61 slot contains the text 'ABCDE', while others are dashed lines.

- ③ Confirm the program stored in the selected place.

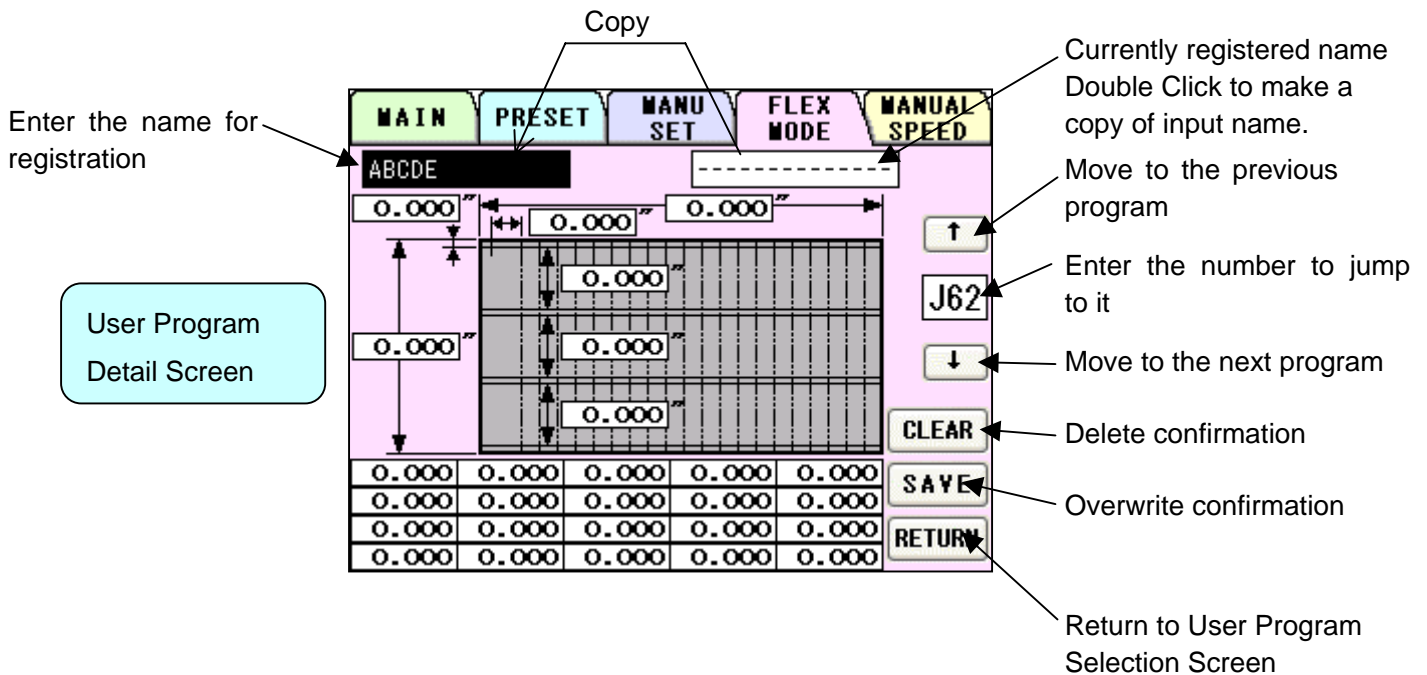

The screen shows a detailed view of a program with a name field containing 'ABCDE' and a grid of numerical values, all set to '0.000'. A 'Copy' label points to the name field. The top navigation bar is the same as in the previous screen. A callout box on the left identifies the screen as the 'User Program Detail Screen'. On the right, several buttons are labeled: an up arrow for 'Move to the previous program', 'J62' for 'Enter the number to jump to it', a down arrow for 'Move to the next program', 'CLEAR' for 'Delete confirmation', 'SAVE' for 'Overwrite confirmation', and 'RETURN' for 'Return to User Program Selection Screen'. A 'Double Click' label points to the name field with the instruction 'Currently registered name Double Click to make a copy of input name.'

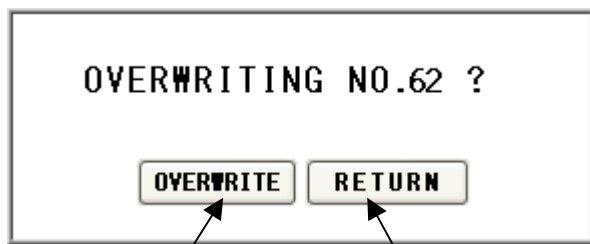
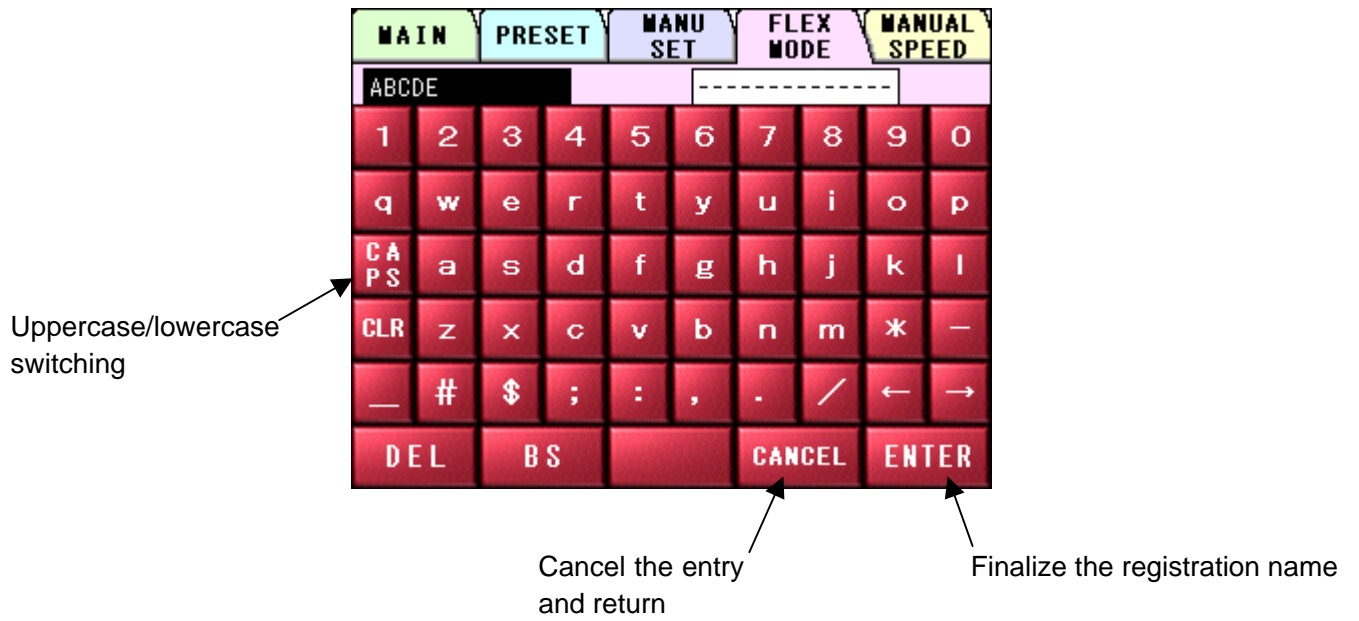

For overwriting and move to Cutting Pattern Correction Screen

Return to User Program Detail Screen

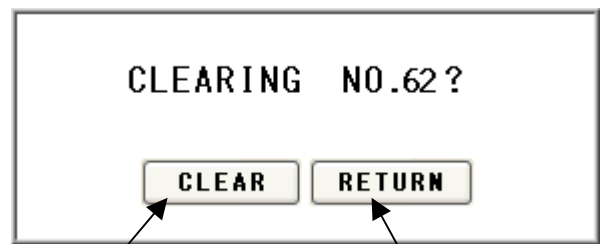

Delete and move to User Program Detail Screen

Return to User Program Detail Screen

(10) Setting of slitter and feed table

- ① By pressing SET, the feed table will be lowered to the bottom dead point and the slitter will move to the operating position.
- ② The display will change from SET to START upon completion.

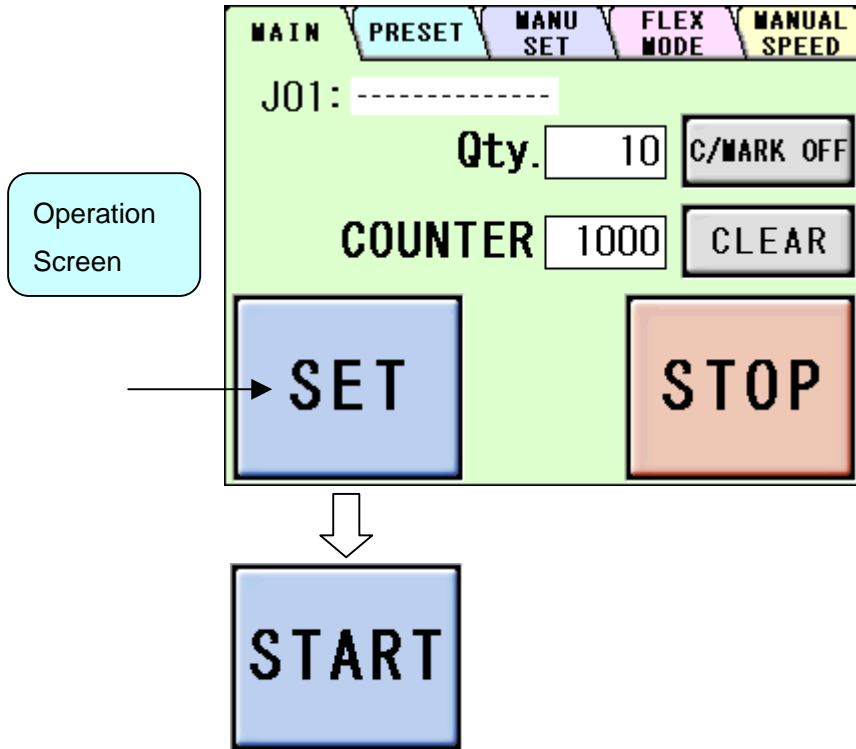

(11) Operation number cancellation

- ① The total number of processed sheets are counted. Press CLR and hold to clear the number. You can change the Total number.

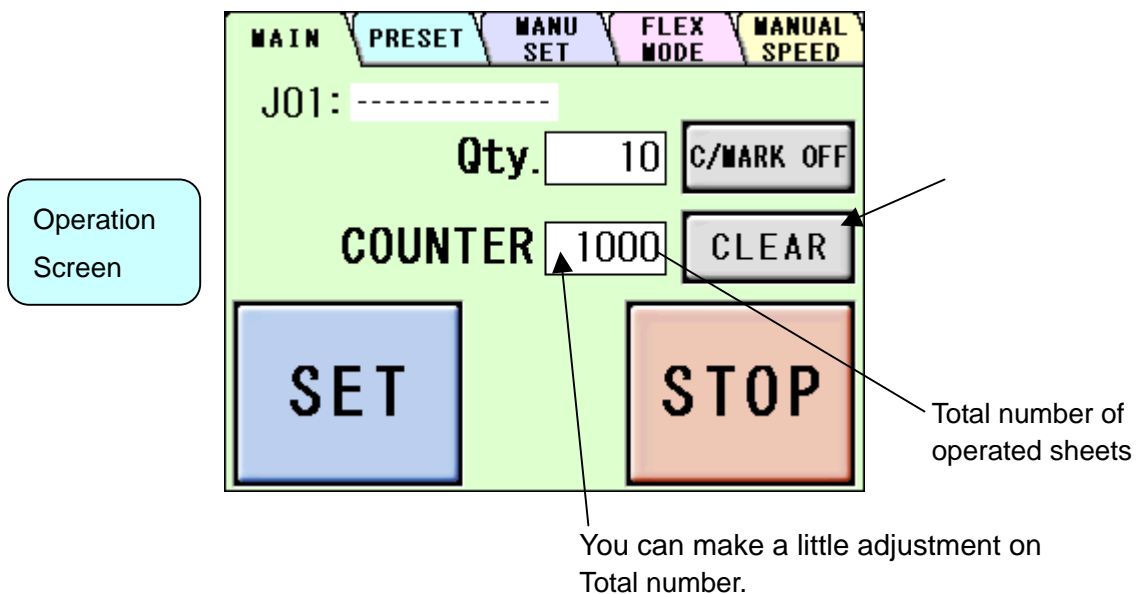

(12) Manual operation and Speed Change

- ① Press MANUAL SPEED.

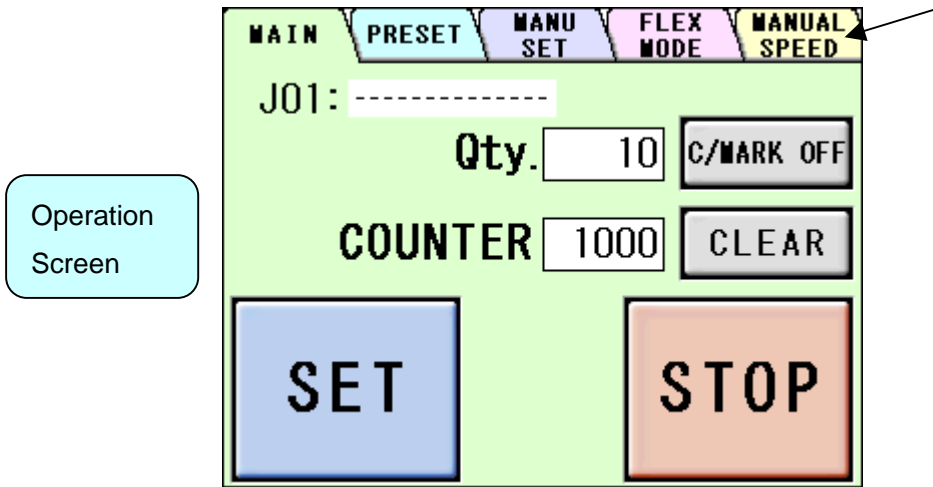

- ② Use it when operating manually.
- ③ There are eight feeding speed levels. The currently selected speed level is inverted to black. Thick paper should not be fed at higher speeds. Please slow the speed down if sheet stops with noise associated.

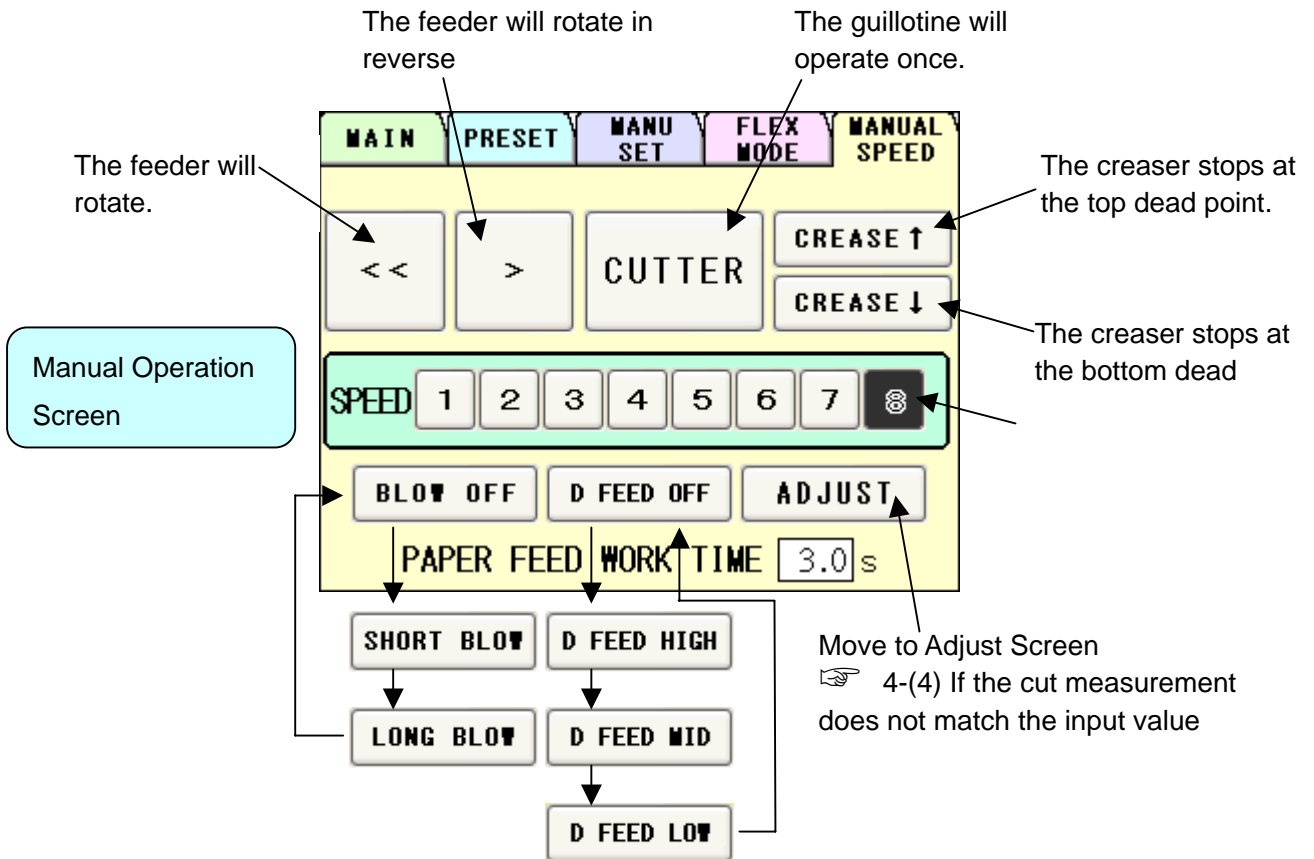

- ④ To avoid double feed or skew feed, adjust PAPER FEED WORK TIME and volume of AIR BLOW.

	SHORT	0.5s~5.0s	LONG
PAPER FEED WORK TIME	Double feed: more likely to occur	↔	Double feed: less likely to occur
	Skew feed: less likely to occur		Skew Feed: more likely to occur

	BLOW OFF	SHORT BLOW	LONG BLOW
AIR BLOW	Double feed: more likely to occur	↔	Double feed: less likely to occur
	Skew feed: less likely to occur		Skew feed: more likely to occur

As a recommended default setting, PAPER FEED WORK TIME should be 0.0 seconds and AIR BLOW should be LONG BLOW.

- ⑤ If double feed is not detected, select D FEED OFF.
- ⑥ If double feed is detected, detection will be affected by the paper thickness and print color. Select a more suitable threshold value from among HIGH, MID, and LOW. Generally, it is more effective to set to HIGH for thin or white paper, and to LOW for thick or dark paper. Double feed detection is performed based on the thickness of the first sheet. It is not effective at all if the first sheet is doubly fed.
- D FEED HIGH: Because of a high threshold value for double feed detection, the machine may react depending on the type of print and paper thickness, even if the paper is not doubly fed.
- D FEED MID: Because of a middle threshold value for double feed, the machine may or may not react, depending on the type of print and paper thickness.
- D FEED LOW: Because of a low threshold value for double feed, the machine may not react, depending on the type of print and paper thickness, even if the paper is doubly fed.

(13) Cut mark on/off selection

Operation Screen

Select C/MARK ON to use cut marks. Select C/MARK OFF for not using cut marks.

(14) Automatic operation

- ① Set the number of sheets for operation. The machine will automatically stop on reaching the set number. Enter "0" for continuous operations.

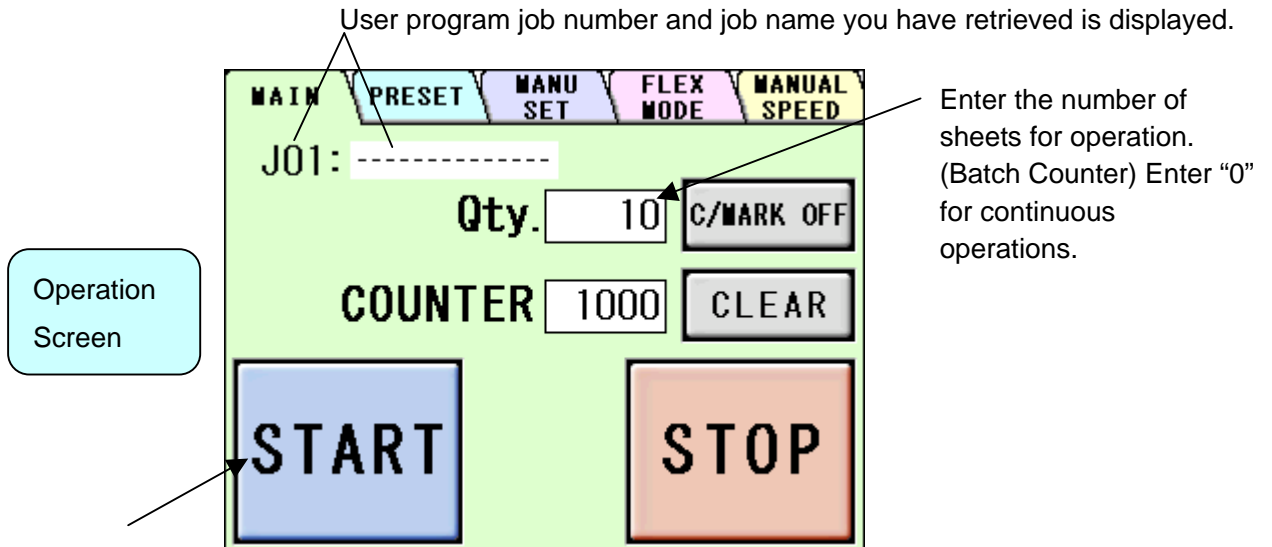

- ② Press START to start an automatic operation. The display will change to RUNNING.
- ③ Press STOP and the machine will make an EMERGENCY stop even if the operation is underway.
- ④ Press END if you wish to stop the machine when the current sheet is completed. The END sign will blink and the machine will automatically stop upon completion of the work.

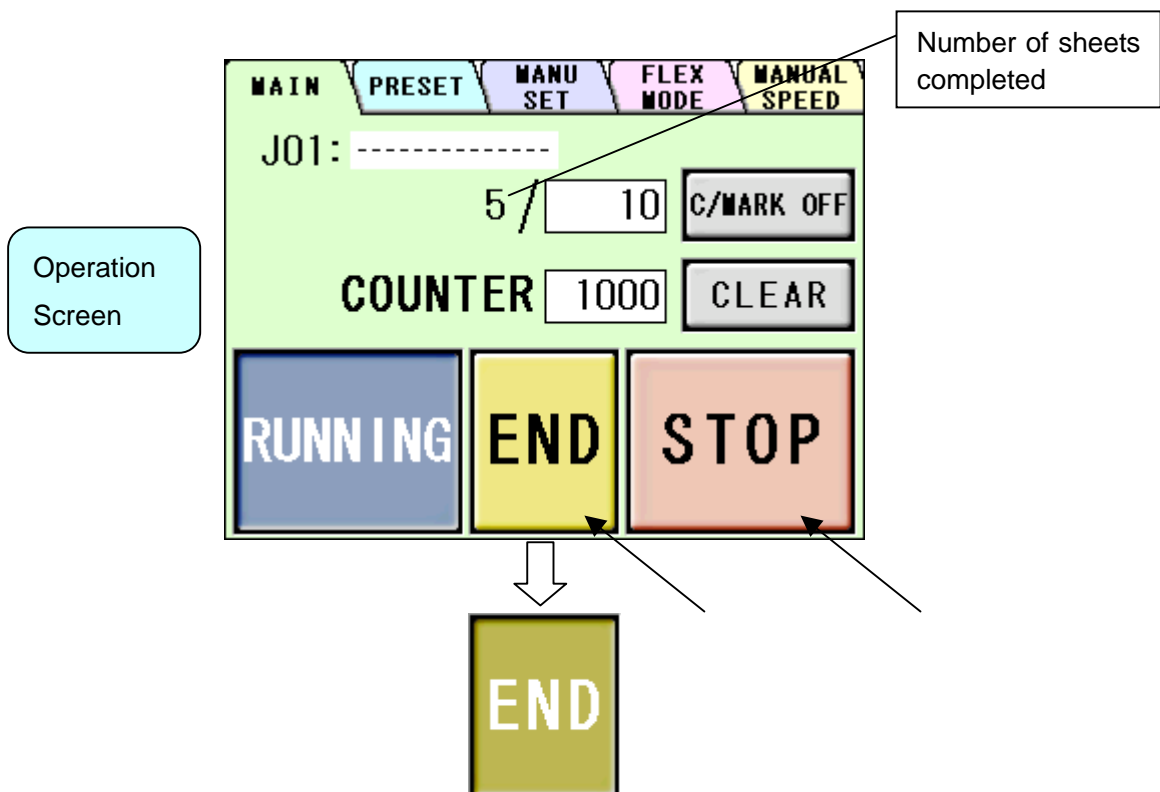

4. Instructions for use



(1) If the machine stops during operation

- ① If the machine stops during operation due to an error such as a paper jam and overloading, paper may still be left in the machine.

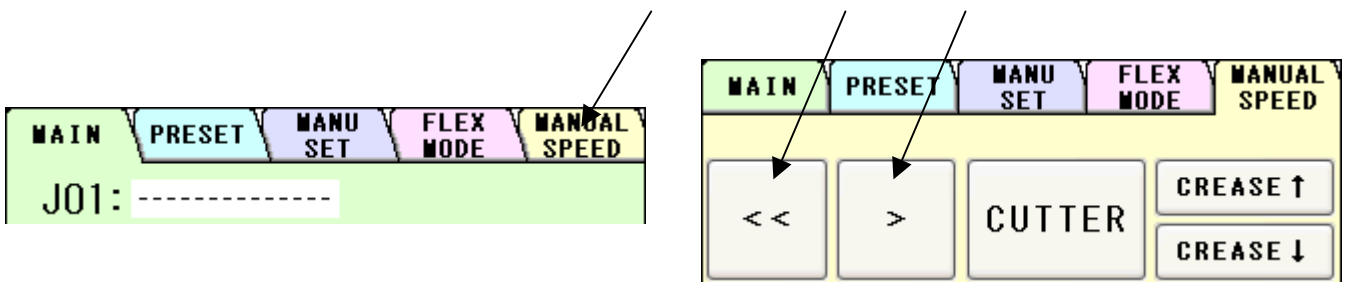

- ② In such a case, the paper must be removed by manual operation, as continuing to operate it may cause a mechanical failure
- ③ Press MANUAL SPEED, and then press << or >> from the screen, or press < or > from the error screens as shown above to move the feeder for paper ejection.



 <h2 style="margin: 0;">Caution</h2>	
	<p>Avoid contacting any rotating object. Otherwise, injury could occur.</p>
	<p>Don't bring a hand, face, hair, sleeves of clothes and the like close to the rotating parts of the machine. There is a danger of receiving an injury.</p>

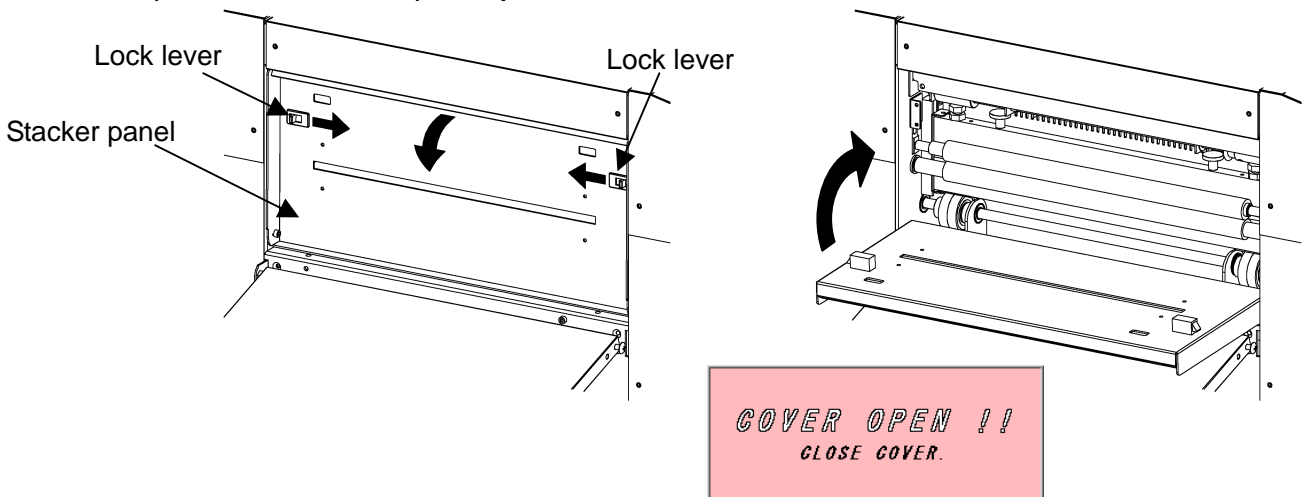

(2) If Paper scrap remains on the machine

- ① When the paper jams near the stacker panel or when maintenance work is done, the stacker panel can be opened.
- ② Shift the right and left lock levers of the stacker panel to the inner side, and pull the upper part by hand to open.
- ③ Pick up paper scraps with Tweezers and take them away.
- ④ With the stacker panel opened, the machine cannot be operated, resulting in Cover open error.
- ⑤ To reposition the stacker panel, just close it.

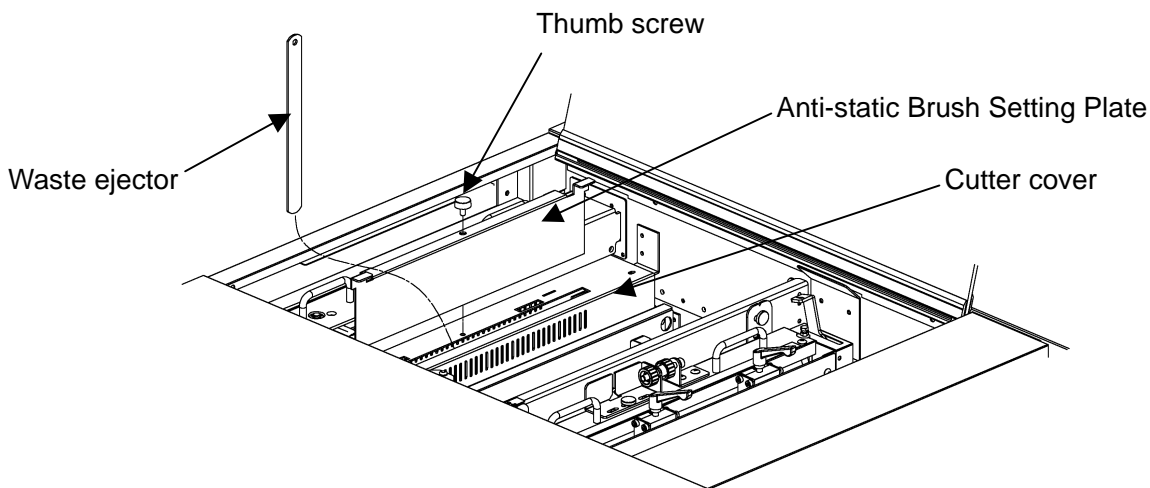

- ⑥ If the paper scrap remains in cutter cover.
If Paper scrap remains under the Cutter cover of the machine, turn off the machine and take off thumb screw to remove the anti-static brush setting plate. After removing plate there will be a space. Push the paper t scrap down with Waste ejector, which comes with machine.



 Caution	
	Power it off. Otherwise, Injury could occur.

(3) Details concerning errors

① Paper size error

Correct the paper size to fit in the value range below.

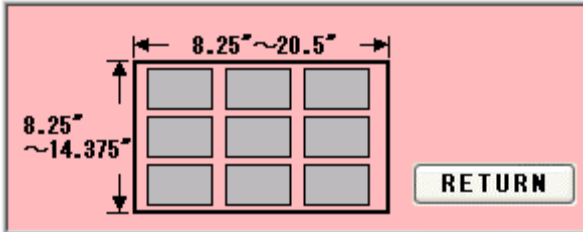

② Final cutting measurement error

Correct the final cutting measurement to exceed the value specified below.

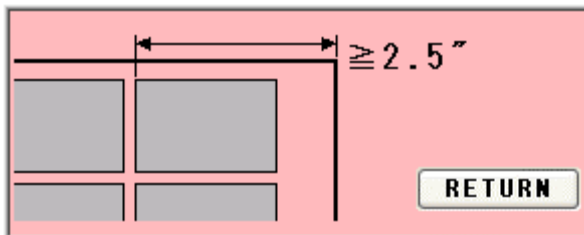

③ Cutting measurement error

Correct the cutting measurement to fit in the value range below. The maximum value is subject to change depending on the entered paper size.

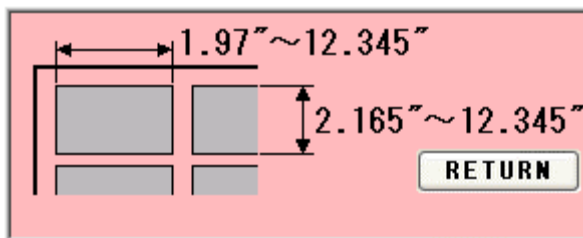

④ Cut piece number error

Correct the number of cut pieces to be in the value range below. The maximum number of pieces is subject to change depending on the operation.

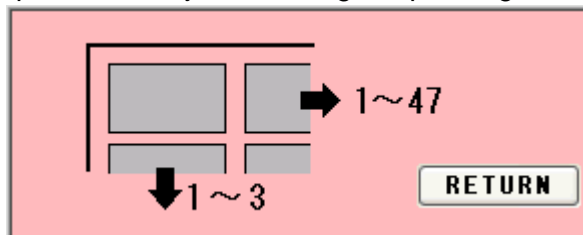

⑤ Bottom margin error

Correct the bottom margin to fit in the value range below.

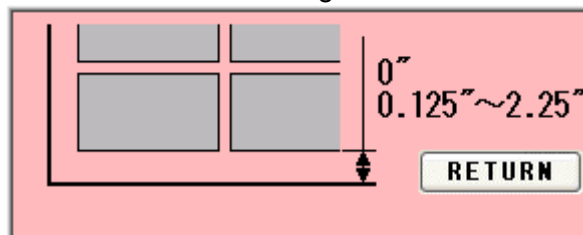

⑥ Top margin error

Correct the top margin to fit in the value range below.

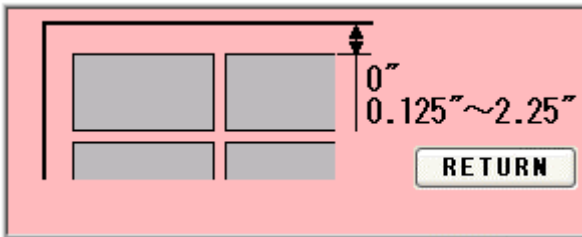

⑦ Back margin error (MANU SET)

Correct the back margin to fit in the value specified below.

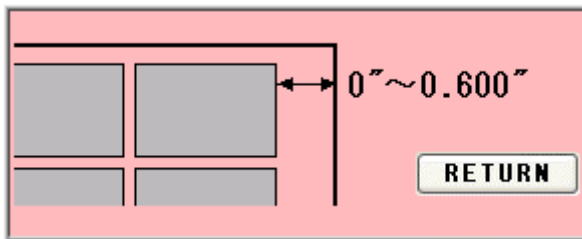

⑧ Back margin error (FLEX MODE)

Correct the back margin to fit in the value specified below.

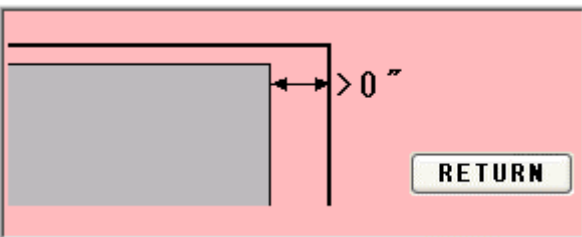

⑨ Crease front margin error

Correct the crease front margin to exceed the value specified below.

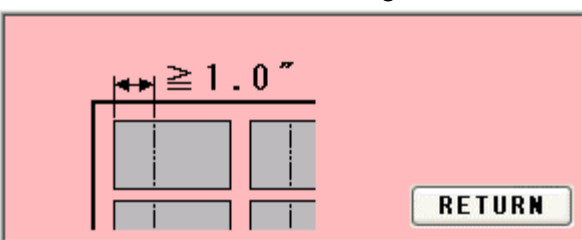

⑩ Crease back margin error

Correct the crease back margin to exceed the value specified below.

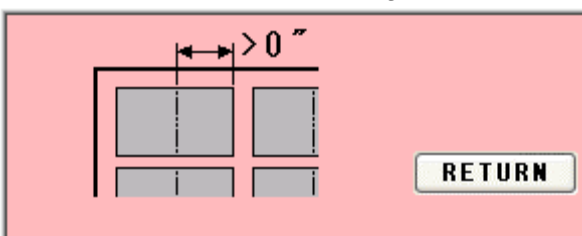

⑪ Perforation location warning

Correct the perforation location to fit in the value range below. The maximum value is subject to change depending on the entered paper size.

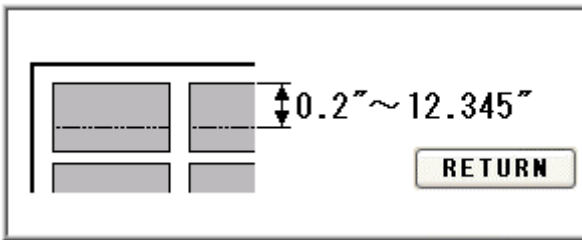

⑫ Leading edge margin and cut mark margin warning

Correct the measurement so that the leading margin becomes larger than the cut mark margin.

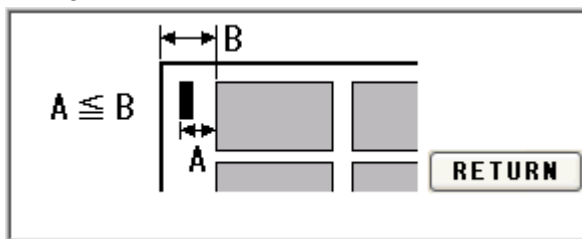

⑬ Cover open error

Safety cover or Stacker panel might be open.

Make sure to close the Safety cover and Stacker Panel is closed.



⑭ Paper jam error

Paper remains inside the machine. Remove the paper.



⑮ Timeout error 1

Paper was not fed within a set time period. Check the paper feeder.



⑩ Timeout error 2

Paper did not pass through within a set time period. Remove the paper remaining inside the machine.



⑪ Overload error 1

Cutting or creasing did not complete within a set time period. Remove the paper remaining inside the machine.



⑫ Overload error 2

An overloading error occurred at the feed table. Check the feed table.



⑬ Overload error 3

An overloading error occurred at the slitter. Check the blinking slitter.



⑭ Cut mark detection error

Cut mark was unable to be detected. Check the cut mark. Eject the paper inside the machine.



②① Double feed detection error

Double feed detected. Check the paper or paper path.



②② Slitter units positioning error

Slitter position is out of valid range. Check paper size and input data.

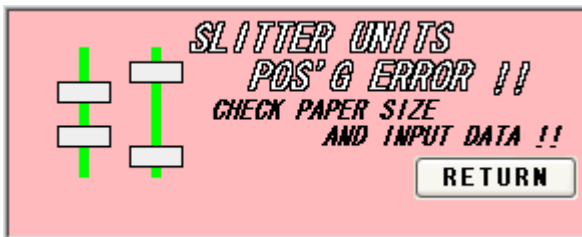

②③ Serial communication error

Communication with the touch panel is not possible. Turn off the power, and turn it on again after 5 seconds or longer.

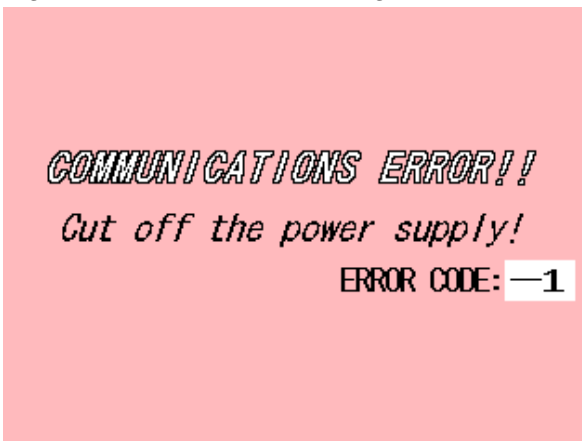

②④ Servo motor error

Servo motor error detected. Turn off the power, and turn it on again after 5 seconds or longer.

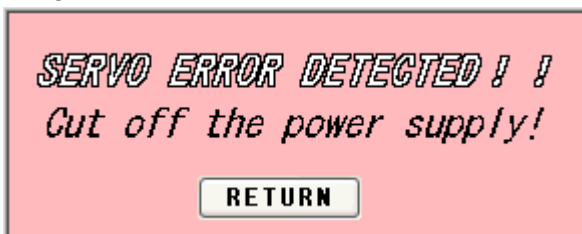

②⑤ Data aren't updated error

This error message appears as a warning when proceeding to another screen without saving the corrected dimensions in the MANU SET or FLEX MODE screen. Press OK if you want to proceed to the other screen; otherwise, press RETURN.



②⑥ FLEX MODE input error

This error results when the three input values shown in the following figure are "0" or lower at FLEX MODE time.

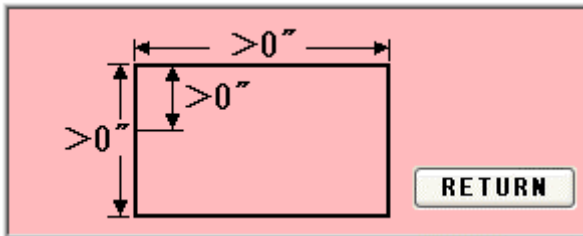

(4) If the cut measurement does not match the input value

- ① If Measurement A is different: When the input value is 0.200" and the actual cut measurement is 0.175", input +0.025"; input -0.040" when the actual cut measurement is 0.240". ※
 - ② If Measurements B, C, or D are different: When the input value is 3.500" and the actual cut measurement is 3.560", input -0.060"; input +0.080" when the actual cut measurement is 3.420". ※
 - ③ If Measurement E is different: When the input value is 0.600" and the actual cut measurement is 0.620", input -0.020"; input +0.050" when the actual cut measurement is 0.550". (You can input ± 0.400 " at the most)
 - ④ If Measurement F (crease location) is different: When the input value is 2.000" and the actual crease measurement is 2.250", input -0.250"; input +0.100" when the actual crease measurement is 1.900". (You can input ± 0.400 " at the most)
 - ⑤ If Measurement G is different: When the input value is 0.400" and the actual cut measurement is 0.450", input -0.050"; input +0.100" when the actual cut measurement is 0.300". (You can input ± 0.400 " at the most)
 - ⑥ Use H and I for magnificent adjustment. If the printed image is bigger or smaller than the one you designate, you can adjust cutting length to fit the printed measurement with this magnificent adjustment. : When the input value is 4.000" and the actual cut measurement is 4.080", input 0.980 ($4.000 \div 4.080$); input 1.010 ($4.000 \div 3.960$) when the actual cut measurement is 3.960". When this measurement is corrected, Measurements E, F and G will need to be corrected as well. Refer to ③–⑤ above and make corrections. (H must be from 0.500 times to 2.000 times and I must be from 0.800 times to 1.200times)
- ※ : If you press OK after you input values into A, B, C and D, those values will be added to each total measurements which are circled on the image below. Then, A, B, C and D will be reset to 0.000. You can change the measurement by 0.002". Each adjustment should be within ± 0.080 " at one time. If the gap is more than ± 0.080 ", repeat the process until the desired measurement is reached.

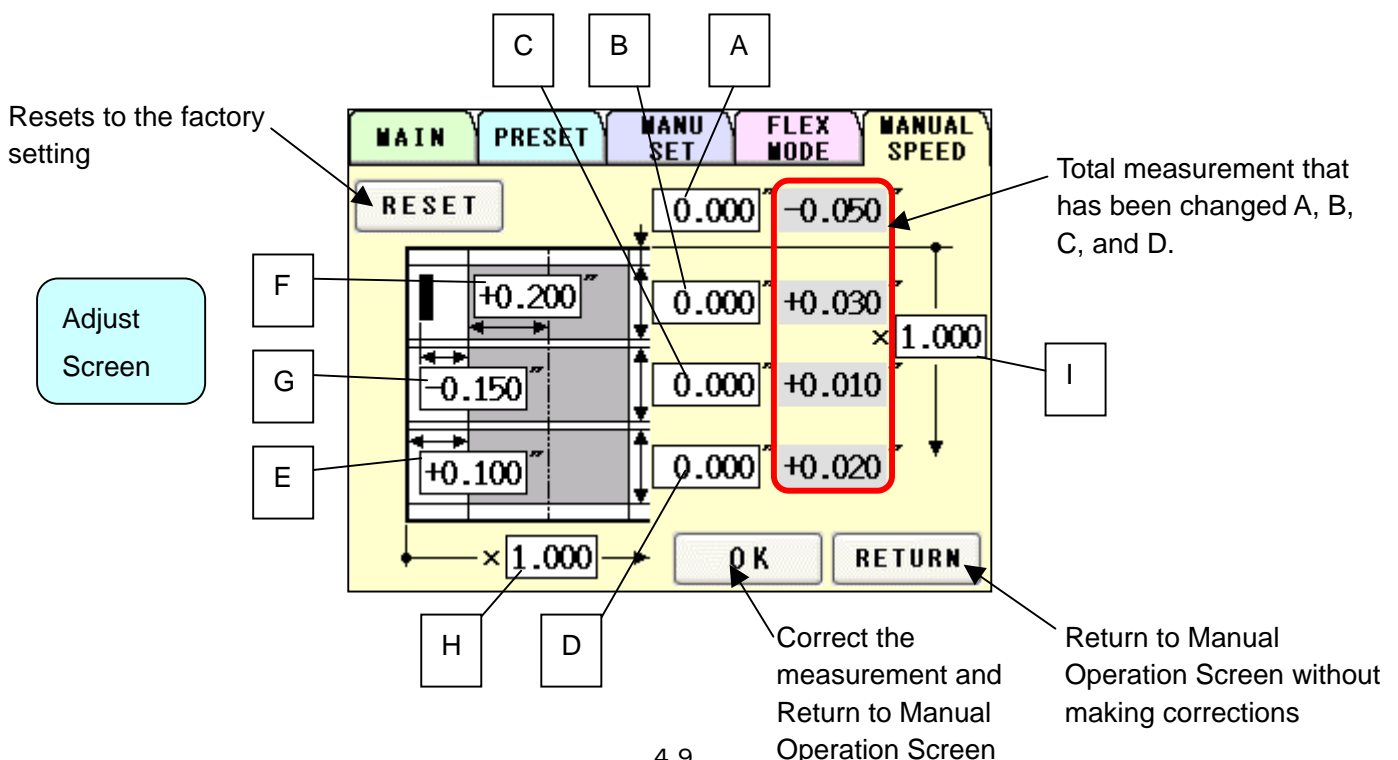

5. Product specifications

Specifications	
Slitter	4 sets (6 slitter blades)
Creaser	1 set (5-level manual crease depth adjustment)
Perforator	2 sets
Number of guillotine or creasing	MAX48times / sheet
Paper size (depth direction)	8.25" (A4 short) ~14.375" (B3 short)
Paper size (feed direction)	8.25" (A4 short) ~20.500" (B3 long)
Finish size	MIN1.97"W × 2.165"D
Paper weight	32 lbs (Bond) – 130 lbs (Cover stock) [120-350g/m ²]
Maximum paper curl size	±0.125"
Paper type	Offset, Coat, UVcoat, Glossy, Laminate
Paper feeding method	Air Suction
Input tray capacity	MAX4.000"
Speed	MAX 12 sheets per minute (in case of eight cut from SRA3 to Postcard)
Machine dimensions	35.8" W × 31.5" D × 42.9" H (Occupancy area: 68.5" W × 31.5" D × 60.6" H)
Net weight	452lbs. (205Kg)
Power supply	Single phase 110-120VAC, 50/60Hz, 3.6A-3.3A
Power consumption	400W
Use temperature	23 to 104°F (-5 to 40°C)
Preservation temperature	-13 to 149°F (-25 to 60°C)
Use temperature humidity	45~85%RH
Preservation humidity	25~100%RH
Use the uplands	~1000M
One's tolerance level	110~120V +6%, -10%
Over voltage category	Category III according to IEC60664-1
Pollution degree	Degree 3 according to IEC60664-1

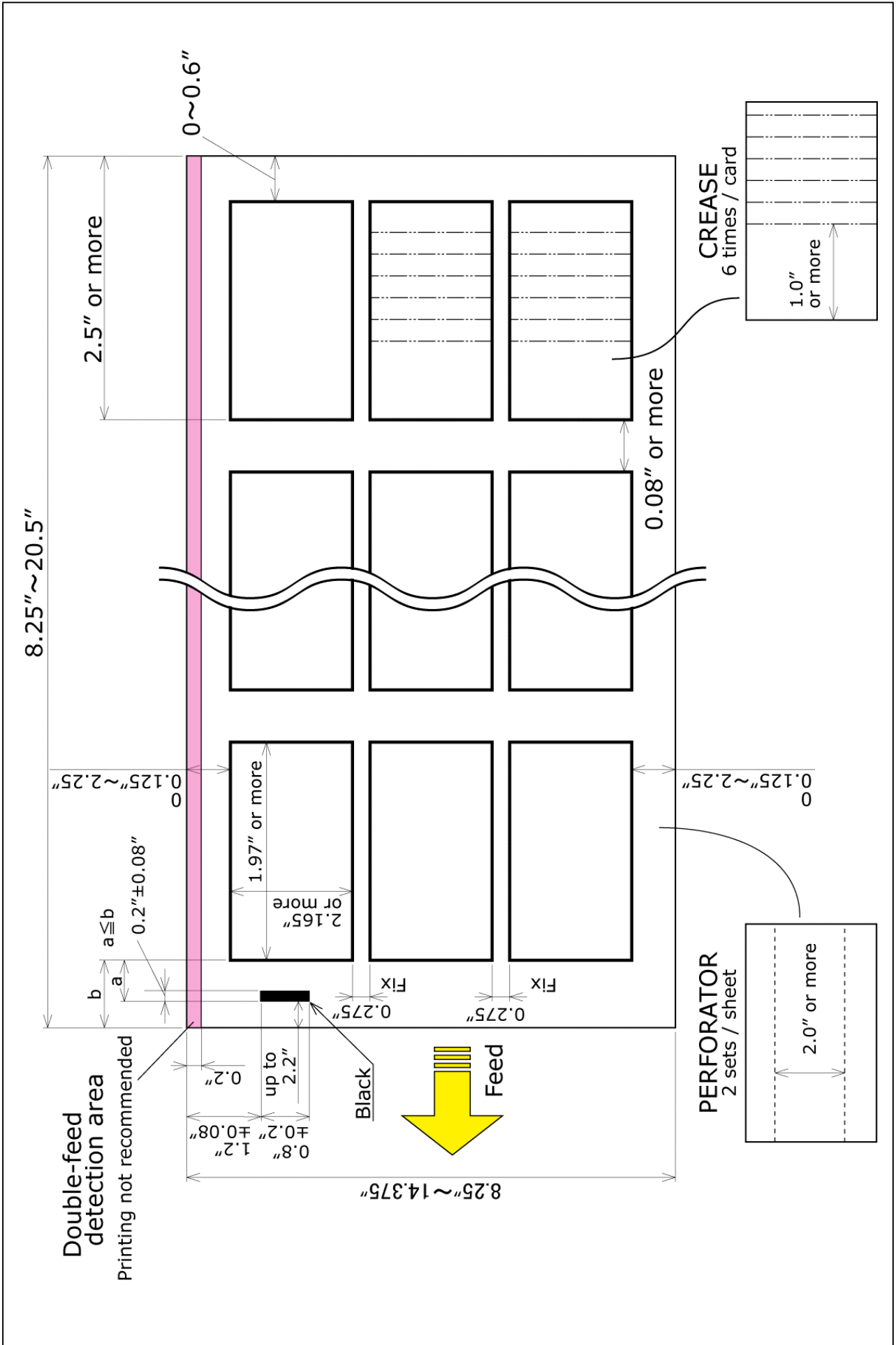

6. Equipment, Electric circuit and parts

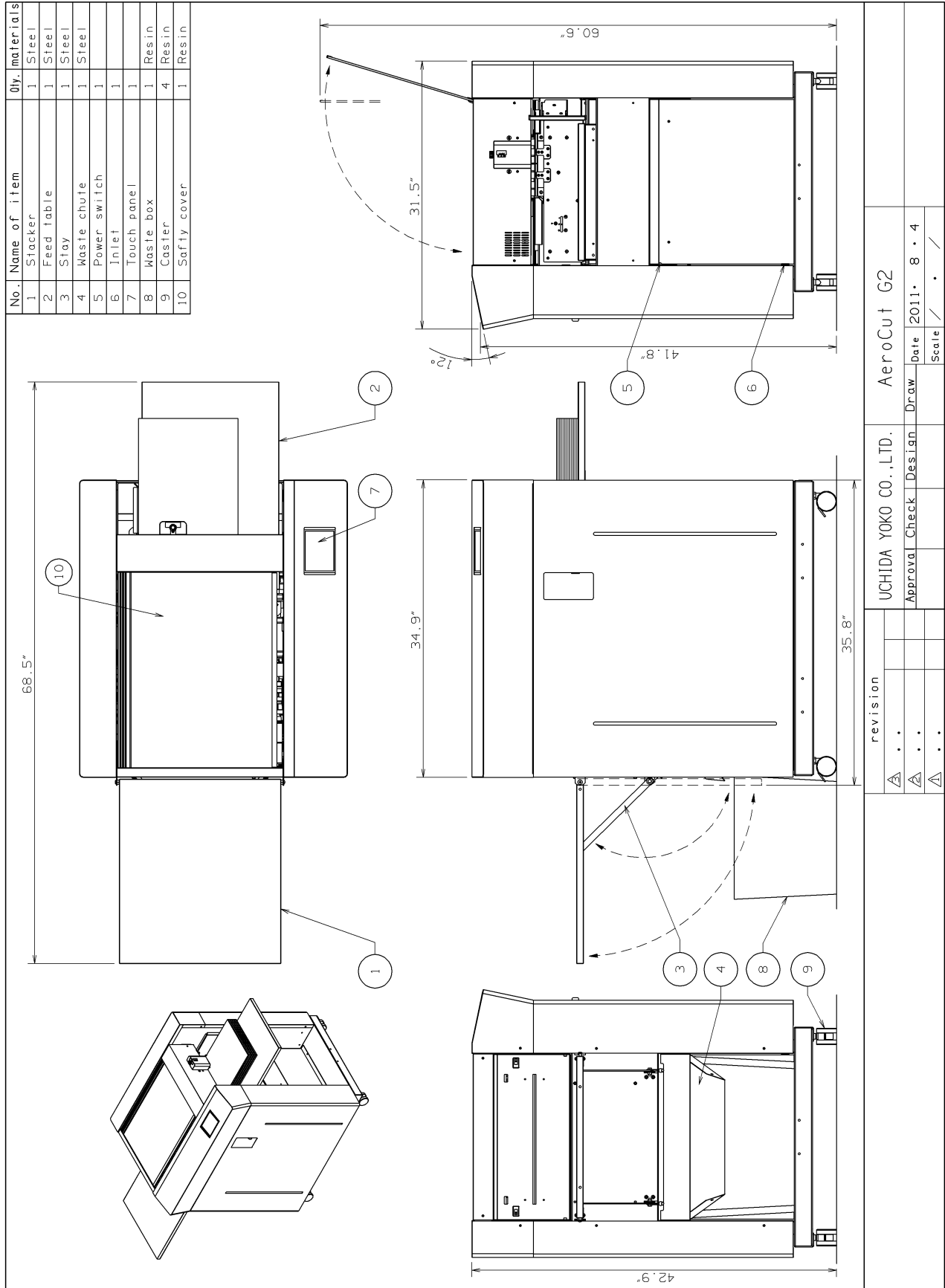

revision		UCHIDA YOKO CO.,LTD.		AeroCut G2	
△	..	Approval	Design	Draw	Date
△	..				2011. 8. 4
△	..			Scale	/ . /

Electric Circuit (V1.00)

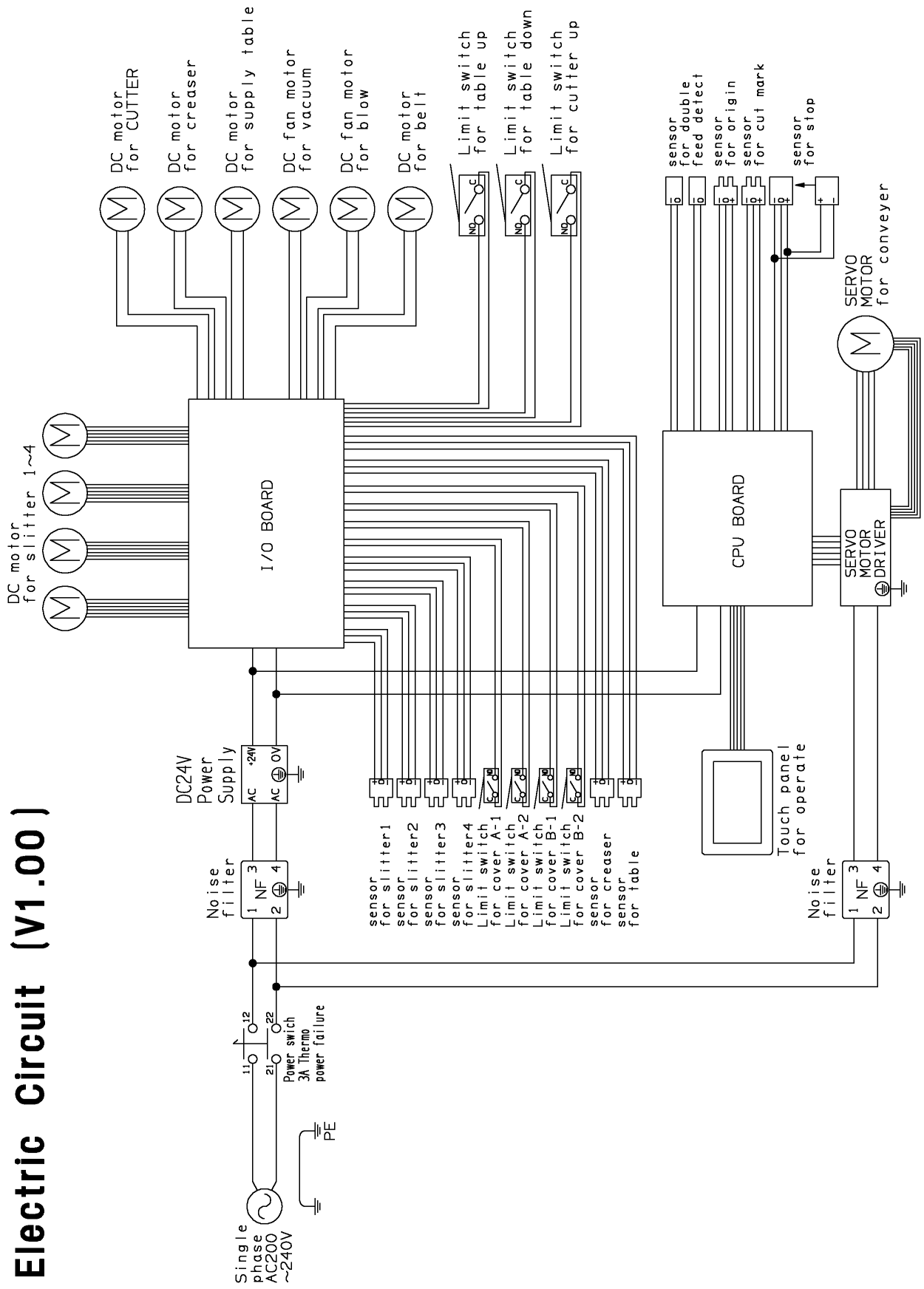

Electric Parts

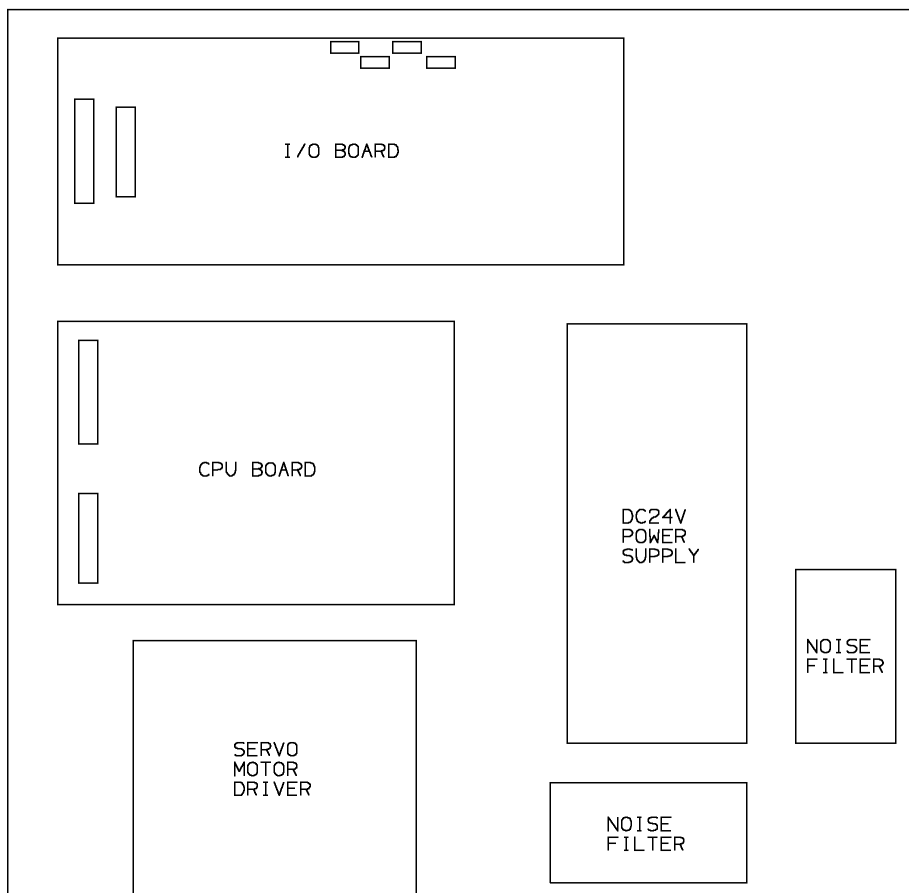

7. Ordering consumables, etc.

When ordering consumables or parts, be sure to specify the machine model.

OPERATION MANUAL

AEROCUT G2

Keep this "Operation Manual" at an appointed place with care so that it may be available whenever required.

If this "Operation Manual" is stained or lost, make contact with the distributor or our salesman or customer service section to ask for a new operation manual after making sure of its contents.